

Self Diagnosis
Supported model

SERVICE MANUAL

FE-2 CHASSIS

MODEL	COMMANDER	DEST	CHASSIS NO.	MODEL	COMMANDER	DEST	CHASSIS NO.
KD-28DX40U	RM-933	UK	SCC-Q52K-A	KD-32DX40U	RM-933	UK	SCC-Q52L-A

FD Trinitron



KD-28/32DX40



RM-933

TRINITRON[®] COLOR TV
SONY[®]

TABLE OF CONTENTS

Section	Title	Page	Section	Title	Page
	Specifications	3	4. CIRCUIT ADJUSTMENTS		
	Connectors	4	4-1.	Electrical Adjustments	21
	Self Diagnostic Software	5	4-2.	Test Mode 1	23
1. GENERAL			4-3.	Test Mode 2	23
	Automatically Tuning the TV	6	5. DIAGRAMS		
	Finding the Video Channel	6	5-1.	Block Diagrams (1)	24
	Selecting Digital or Analogue Mode	6		Block Diagrams (2)	25
	The Programme Index Table	6		Block Diagrams (3)	26
	The Channel Index Menu	6	5-2.	Circuit Board Location	27
	Viewing Digital Teletext	7	5-3.	Schematic Diagrams and Printed Wiring Boards	27
	Teletext(Analogue)	8		* A Board	29
	The Digital EPG Menu	8		* C Board	32
	The Digital INFO Display	9		* VM Board	33
	The TV Menu System	10		* A1 Board	34
	The Set Up Menu	11		* B Board	36
	Remote Control of Equipment	12		* H2 Board	36
	Troubleshooting	12		* D3 Board	37
2. DISASSEMBLY				* H8 Board	37
	2-1. Rear Cover Removal	13		* F3 Board	37
	2-2. Side Control Module Removal	13		* D2 Board	37
	2-3. Chassis Removal	13		* F6 Board	37
	2-4. Service Position	14	5-4.	Semiconductors	38
	2-5. F6 and H8 Board Removal	14	5-5.	IC Blocks	40
	2-6. N Board Removal	14	6. EXPLODED VIEWS		
	2-7. Picture Tube Removal	15	6-1.	Chassis	41
	Bottom Plates	16	6-2.	Picture Tube	42
3. SET-UP ADJUSTMENTS			7. ELECTRICAL PARTS LIST		43
	3-1. Beam Landing	17			
	3-2. Convergence	18			
	3-3. Focus Adjustment	20			
	3-4. Screen (G2), White Balance	20			

CAUTION

SHORT CIRCUIT THE ANODE OF THE PICTURE TUBE AND THE ANODE CAP TO THE METAL CHASSIS, CRT SHIELD, OR THE CARBON PAINTED ON THE CRT, AFTER REMOVAL OF THE ANODE CAP.

WARNING !!

AN ISOLATION TRANSFORMER SHOULD BE USED DURING ANY SERVICE WORK TO AVOID POSSIBLE SHOCK HAZARD DUE TO LIVE CHASSIS, THE CHASSIS OF THIS RECEIVER IS DIRECTLY CONNECTED TO THE POWER LINE.

SAFETY-RELATED COMPONENT WARNING !!

COMPONENTS IDENTIFIED BY SHADING AND MARKED Δ ON THE SCHEMATIC DIAGRAMS, EXPLODED VIEWS AND IN THE PARTS LIST ARE CRITICAL FOR SAFE OPERATION. REPLACE THESE COMPONENTS WITH SONY PARTS WHOSE PART NUMBERS APPEAR AS SHOWN IN THIS MANUAL OR IN SUPPLEMENTS PUBLISHED BY SONY.

ATTENTION

APRES AVOIR DECONNECTE LE CAP DE'LANODE, COURT-CIRCUITER L'ANODE DU TUBE CATHODIQUE ET CELUI DE L'ANODE DU CAP AU CHASSIS METALLIQUE DE L'APPAREIL, OU AU COUCHE DE CARBONE PEINTE SUR LE TUBE CATHODIQUE OU AU BLINDAGE DU TUBE CATHODIQUE.

ATTENTION !!

AFIN D'EVITER TOUT RISQUE D'ELECTROCUTION PROVENANT D'UN CHÂSSIS SOUS TENTION, UN TRANSFORMATEUR D'ISOLEMENT DOIT ETRE UTILISÉ LORS DE TOUT DÉPANNAGE LE CHÂSSIS DE CE RÉCEPTEUR EST DIRECTMENT RACCORDÉ À L'ALIMENTATION SECTEUR.

ATTENTION AUX COMPOSANTS RELATIFS À LA SECURITÉ!!

LES COMPOSANTS IDENTIFIÉS PAR UNE TRAME ET PAR UNE MARQUE Δ SUR LES SCHÉMAS DE PRINCIPE, LES VUES EXPLOSÉES ET LES LISTES DE PIÈCES SONT D'UNE IMPORTANCE CRITIQUE POUR LA SÉCURITÉ DU FONCTIONNEMENT, NE LES REMPLACER QUE PAR DES COMPSANTS SONY DONT LE NUMÉRO DE PIÈCE EST INDIQUÉ DANS LE PRÉSENT MANUEL OU DANS DES SUPPLÉMENTS PUBLIÉS PAR SONY.

ITEM MODEL	Television System	Stereo System	Channel Coverage	Color System
U	I	NICAM Stereo	I UHF : E21-E69	PAL, SECAM NTSC4.43, NTSC3.58 (VIDEO IN)

Picture Tube	Flat Display FD Trinitron Approx 71 cm (28 inches) (Approx 66 cm picture measured diagonally) KD-28DX40U Approx 82 cm (32 inches) (Approx 76 cm picture measured diagonally) KD-32DX40U	Sound output	
		Right and Left speaker	2x14W (Music Power) 2x7W (RMS)
Input/Output Terminals [REAR]		General Specifications	
1: 21-pin Euro connector (CENELEC standard)	Inputs for Audio and Video signals. Inputs for RGB. Outputs of TV Video and Audio signals.	Power Requirements	220 - 240V
		Power Consumption	90 W (KD-28DX40) 88 W (KD-32DX40)
2: 21-pin Euro connector	Inputs for Audio and Video signals. Inputs for S Video. Outputs of TV Video and Audio signals. (selectable)	Dimensions	Approx 806x497x540mm (KD-28DX40) Approx 891x564x584mm (KD-32DX40)
		Weight	Approx 43kg (KD-28DX40) Approx 60.5kg (KD-32DX40)
Phono Jacks	Output Connectors variable for Audio Signals	Supplied Accessories	RM-933 Remote Commander (1) IEC designated R6 battery (2)
Digital	Modem Jack PCMCIA	Other Features	TV system Autodetection, Teletext Virtual Dolby
Input/Output Terminals [SIDE]		Remote Control System : Infrared Control	
Headphone jack	stereo mini jack	Power requirements	3V dc 2 batteries IEC designation R6 (size AA)
Audio inputs	phono jacks		
Video inputs	phono jacks		
S Video input	4 pin DIN		
Design and specifications are subject to change without notice.			

Model Name Item	KD-28DX40U	KD-32DX40U
Pal Comb	OFF	OFF
PIP	OFF	OFF
RGB Priority	ON	ON
Woofers Box	OFF	OFF
Scart 1	ON	ON
Scart 2	ON	ON
Front in (3)	ON	ON
Scart 4	OFF	OFF
Projector	OFF	OFF
Norm B/G	OFF	OFF
Norm I	ON	ON
Norm D/K	OFF	OFF
Norm AUS	OFF	OFF
Norm L	OFF	OFF
Norm SAT	OFF	OFF
Norm M	OFF	OFF
Teletext	ON	ON
Nicam Stereo	ON	ON

WARNING (UK Models only)

The flexible mains lead is supplied connected to a **B.S. 1363** fused plug having a fuse of **5 AMP** rating. Should the fuse need to be replaced, use a **5 AMP FUSE** approved by ASTA to **BS 1362**, ie one that carries the  mark.

IF THE PLUG SUPPLIED WITH THIS APPLIANCE IS NOT SUITABLE FOR THE OUTLET SOCKETS IN YOUR HOME, IT SHOULD BE CUT OFF AND AN APPROPRIATE PLUG FITTED. THE PLUG SEVERED FROM THE MAINS LEAD MUST BE DESTROYED AS A PLUG WITH BARED WIRES IS DANGEROUS IF ENGAGED IN A LIVE SOCKET.

When an alternative type of plug is used, it should be fitted with a **5 AMP FUSE**, otherwise the circuit should be protected by a **5 AMP FUSE** at the distribution board.

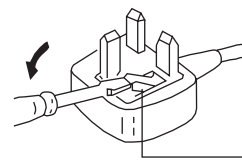

How to replace the fuse.
Open the fuse compartment with a screwdriver blade and replace the fuse.

FUSE

21 pin connector

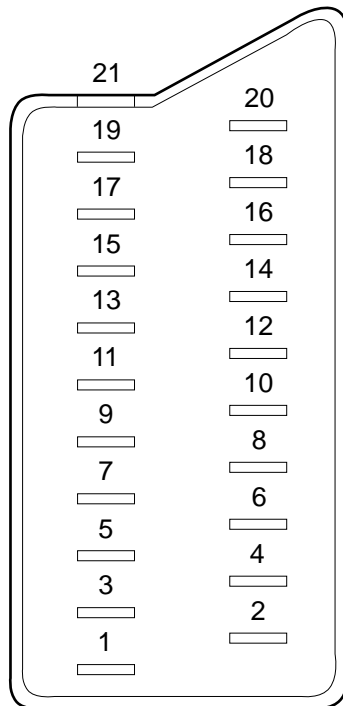

Pin No	1	2	4	Signal	Signal level
1	○	○	○	Audio output B (right)	Standard level : 0.5V rms Output impedance : Less than 1kohm*
2	○	○	○	Audio output B (right)	Standard level : 0.5V rms Output impedance : More than 10kohm*
3	○	○	○	Audio output A (left)	Standard level : 0.5V rms Output impedance : Less than 1kohm*
4	○	○	○	Ground (audio)	
5	○	○	○	Ground (blue)	
6	○	○	○	Audio input A (left)	Standard level : 0.5V rms Output impedance : More than 10kohm*
7	○	●	●	Blue input	0.7 +/- 3dB, 75 ohms positive
8	○	○	○	Function select (AV control)	High state (9.5-12V) : Part mode Low state (0-2V) : TV mode Input impedance : More than 10K ohms Input capacitance : Less than 2nF
9	○	○	○	Ground (green)	
10	○	○	○	Open	
11	○	●	●	Green	Green signal : 0.7 +/- 3dB, 75 ohms, positive
12	○	○	○	Open	
13	○	○	○	Ground (red)	
14	○	○	○	Ground (blanking)	
15	○	-	-	Red input	0.7 +/- 3dB, 75 ohms, positive
	-	○	○	(S signal Chroma input)	0.3 +/- 3dB, 75 ohms, positive
16	○	●	●	Blanking input (Ys signal)	High state (1-3V) Low state (0-0.4V) Input impedance : 75 ohms
17	○	○	○	Ground (video output)	
18	○	○	○	Ground (video input)	
19	○	○	○	Video output	1V +/- 3dB, 75ohms, positive sync 0.3V (-3+10dB)
20	○	-	-	Video input	1V +/- 3dB, 75ohms, positive sync 0.3V (-3+10dB)
	-	○	○	Video input Y (S signal)	1V +/- 3dB, 75ohms, positive sync 0.3V (-3+10dB)
21	○	○	○	Common ground (plug, shield)	

○ Connected ● Not Connected (open) * at 20Hz - 20kHz

Rear Connection Panel

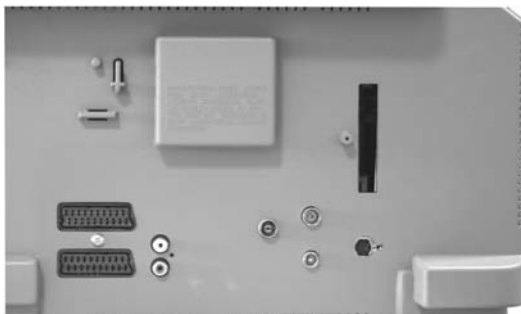

Front Connection Panel



S-Video socket

S Video socket pin configuration		
Pin No	Signal	Signal Level
1	Ground	-
2	Ground	-
3	Y (S signal) input	1V +/- 3dB 75ohm, positive Sync. 0.3V -3 +10dB
4	C (S signal) input	0.3V +/- 3dB 75ohm, positive Sync.

FE-2 SELF DIAGNOSTIC SOFTWARE

The identification of errors within the FE-2 chassis is triggered in one of two ways :- 1: Busy or 2: Device failure to respond to IIC. In the event of one of these situations arising the software will first try to release the bus if busy (Failure to do so will report with a continuous flashing LED) and then communicate with each device in turn to establish if a device is faulty. If a device is found to be faulty the relevant device number will be displayed through the LED (Series of flashes which must be counted) See table 1., non fatal errors are reported using this method. Each time the software detects an error it is stored within the NVM. See Table 2.

Table 1

Error Message	LED Code
No error	00
Reserved	01
OCP (Over Current Protection)	02
Not Used	03
No Vertical Sync	04
IKR Error at power on	05
IIC bus clock and/or data lines low at power on	06
NVM no IIC bus acknowledge at power on	07
Not Used	08
Tuner no acknowledge at power on	09
Sound Processor Error	10
Jungle controller 8 volts error	11

How to enter into Table 2

1. Turn on the main power switch of the TV set and enter into the 'Standby Mode'.
2. Press the following sequence of buttons on the Remote Commander.

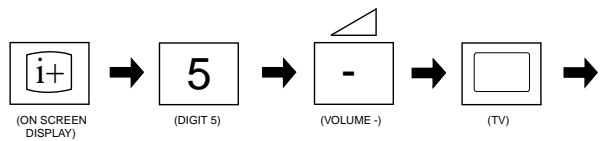

3. The following table will be displayed indicating the error count.

Flash Timing Example : e.g. error number 3

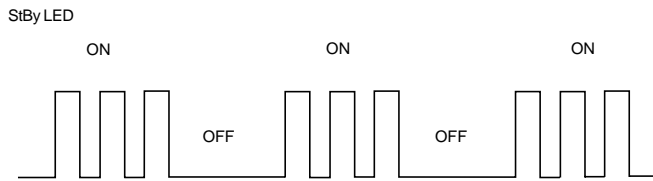

Table 2

ERROR MENU			
E02	OCP	(0, 255)	0
E03	OVP N/A	(0, 255)	0
E04	VSYNC	(0, 255)	0
E05	IKR	(0, 255)	0
E06	IIC	(0, 255)	0
E07	NVM	(0, 255)	0
E08	JUNGLE	(0, 255)	0
E09	TUNER	(0, 255)	0
E10	SOUNDP	(0, 255)	0
E11	8V	(0, 255)	0
WORKING TIME			
HOURS			2
MINUTES			11

Note: To clear the error count data press '80' on the Remote commander.

The operating instructions mentioned here are partial abstracts from the 'Operating Instruction Manual'. The page numbers of the 'Operating Instruction Manual' remain as in the manual.

5. Automatically tuning the TV



1. When you switch on the TV for the first time a menu appears on the screen asking you to check if the picture is slanted. (Sometimes the Earth's natural magnetism can cause the screen to look tilted.)

Checking the picture tilt.



a) If no correction is required, press the \blacktriangle or \blacktriangledown buttons on the remote control to highlight 'Not necessary' and press the OK button.

b) If some correction is required, press the \blacktriangle or \blacktriangledown buttons on the remote control to highlight 'Adjust now', then press the OK button. Correct the slant by pressing the \blacktriangle or \blacktriangledown buttons then press the OK button to store.

2. The autotune prompt screen appears. Press the OK button to select 'Yes'. The autotune procedure begins.

The autotune prompt screen.



The Digital autotune display appears on screen and the search and store procedure begins. All the available Digital channels will now be captured and stored. As this may take some time, a message is included in the display to inform you of the tuning progress.

When Digital tuning is complete, the analogue display appears automatically and the search and store procedure for the analogue channels begins.

If no Digital and no analogue channels are found, a menu appears asking you to confirm your aerial is connected. After checking the aerial has been connected press OK to begin the autotune procedure again.

Tuning the Digital channels.



Once all Digital and analogue channels have been captured and stored, the TV returns to normal operation and displays the Digital channel captured on channel number 1.

Note: If no Digital channels are captured, the analogue channel that is stored on channel number 1 is displayed.

Tuning the analogue channels.



3. To view programmes, press the PROG +/- buttons or the numbered buttons.

6. Finding the video channel



If you connected a VCR to your TV when following the 'Connecting an aerial and a VCR' instructions, you will now need to find your video channel. Ensure the TV is in analogue mode. If it is not, press the DIGITAL/□ button on the remote control.

1. Press the PROG +/- buttons on the remote control until the picture from the pre-recorded tape appears on the TV screen.

Notes: If you wish to move your video channel to a different programme number, refer to 'The Set Up menu' section of this manual.

If you have connected your VCR using a scart lead, press the \square button on the remote control until the picture from the pre-recorded tape appears on the TV screen. (Refer to 'Connecting additional equipment').

Selecting Digital or analogue mode

Press the DIGITAL/□ button on the remote control to switch between Digital and analogue mode. To check if you are watching a Digital or analogue mode press the PROG +/- button. If you are watching a digital programme a banner will appear momentarily at the top of the screen.

The Programme Index table

The 'Programme Index table' is a quick and easy way to search for a channel you wish to view. The 'Programme Index table' is only available in analogue mode.

1. Press the OK button to display the 'Programme Index table' on screen.



2. Press the \blacktriangle or \blacktriangledown button to scroll through the list until the channel you wish to view is highlighted.

3. Press the OK button to display your chosen channel on the TV screen.

The Channel Index menu

The 'Channel Index menu' provides you with a quick and easy way to:-

- View a complete list of the programmes available for selection,
- Obtain a preview of the programmes contained in the list,
- Search for a programme quickly by selecting from different categories of programmes,
- Store programmes into a list of favourites.



The 'Channel Index menu' is only available in Digital mode.

1. Press the OK button on the remote control to display the 'Channel Index menu' on the TV screen. The menu contains a list of all the available channels. The name of the programme currently being shown along with its start and finish times is shown for each of the available channels. The current channel is previewed in the top right corner of the screen with its channel name and number displayed below it.

2. Press the \blacktriangle or \blacktriangledown buttons to move the coloured cursor up or down the list to select the desired programme. If you do not want to select a programme from the 6 channels listed, press the GREEN button to display the next 6 programmes or the RED button to display the preceding 6 channels.

3. Press the OK button to display the highlighted programme in the preview window*.

4. Press the OK button to exit the 'Channel Index menu'. The programme that was being previewed will be displayed.

***Note:** If an age limit for viewing has been set and the programme selected exceeds that age limit, you will need to enter your PIN code before the preview is displayed. Refer to 'The Main Menu' for more information on the 'PIN Code' feature. Programmes that exceed the age limit you have set will be identified by a \blacksquare symbol.

The Category pop-up list

The 'Category' pop-up list allows you to quickly search for a programme by choosing from different categories of programmes.

1. With the 'Channel Index menu' on screen, press the YELLOW button to display the 'Category' pop-up list.



2. Press the \blacktriangle or \blacktriangledown buttons to highlight the required category. The category you choose will be displayed in a title bar at the top of the programme list along with the date and time.
3. Press the OK button. The 'Channel Index menu' will now contain only programmes of the type selected.

The following categories are available:

Favourite Choice	Contains all the programmes you have stored as a favourite (see below). The TV will create this list based on the type of programmes you watch the most.
Recent Prog.	Contains the last 5 programmes watched.
All Categories	Contains all available channels.
Sports	Contains all sport channels.
News	Contains all news channels.
Film	Contains all film channels.
Entertainment	Contains all entertainment channels.
Lifestyle	Contains all lifestyle channels.
Education	Contains all education channels.
Kids	Contains all kids channels.

Favourite programmes

This feature allows you to create a list of your favourite programmes.

To add a programme to the Favourite list

1. With the 'Channel Index menu' on screen, press the \blacktriangle or \blacktriangledown buttons to highlight the programme you want as a favourite.
2. Press the BLUE button to store the programme in the favourite list.

To remove a programme from the Favourite list

1. With the 'Channel Index menu' on screen, press the YELLOW button to access the 'Category' pop-up list.
2. Highlight the 'Favourite' category. Press the OK button to display the 'Favourite list'.
3. Highlight the programme you wish to remove from the 'Favourite list'.
4. Press the BLUE button to remove the programme.



Viewing Digital Teletext

Many broadcasters now provide a Digital Teletext service in the form of a dedicated Teletext channel. This Digital service includes high quality text and graphics along with advanced navigation options.

The appearance, content and navigation methods of all Digital Text services are decided by the broadcaster. For example, Digital Text from the BBC may look different to Digital Text from ITV which may use different navigation methods. Most of the Digital Text services currently available use simple navigation methods based on the following buttons:

- The \blacktriangle , \blacktriangledown , \blacktriangleleft and \blacktriangleright buttons (to move around the screen),
- The OK button (to select items on screen),
- The \odot button (to cancel),
- The four coloured buttons (to access shortcuts).

Dedicated Digital Teletext channels

1. If the TV is not already in Digital mode, press the DIGITAL/□ button on the remote control. Press the numbered buttons on the remote control to select a dedicated Teletext channel number. To find out the channel number of a dedicated Digital Teletext channel, use the 'Channel Index menu'. (Please refer to the 'Changing channels' section of this instruction manual.)



2. Once the Teletext channel is displayed, press the \blacktriangle , \blacktriangledown , \blacktriangleleft or \blacktriangleright buttons as instructed on the screen to select your requirement, then press the OK button to display the chosen information.

Note: On some pages the TV programme is also displayed. Instructions on screen will tell you how to change the displayed programme.

3. If when viewing the Teletext pages, you are requested to select 'OK' or 'Cancel', press the OK button for 'OK' and the \odot button for 'Cancel'.
4. When you have finished viewing Teletext, press the PROG +/- buttons to exit.



Selecting Teletext from other Digital channels

Normal Teletext services may also be available on other Digital channels. Sometimes this is indicated by a small symbol or text display on your TV screen, superimposed on the channel you are watching.

1. Press the \blacktriangle , \blacktriangledown , \blacktriangleleft or \blacktriangleright buttons to select the symbol then press the OK button to display the chosen information.
2. Alternatively, you may be requested to use the numbered and coloured buttons on your remote control to display the various pages of text information. If when viewing the teletext pages, you are requested to select 'OK' or 'Cancel', press the OK button for 'OK' and the \odot button for 'Cancel'.
3. Once the text information is displayed on screen, use the \blacktriangle , \blacktriangledown , \blacktriangleleft or \blacktriangleright buttons, the coloured buttons and/or the numbered buttons to access the chosen information.
4. When you have finished viewing Teletext, press the TV button and then select an alternative Digital channel.



Teletext (Analogue)

Most analogue TV channels broadcast a Teletext service. The index page (usually page 100) provides information on how to use the service. Please ensure you are receiving a good signal, or some Teletext errors may occur.

Switching Teletext on and off

1. If the TV is not already in analogue mode, press the DIGITAL/□ button on the remote control. Select the analogue TV channel which carries the Teletext service you want to view.
2. Press the [] button to enter Teletext mode, then using the numbered buttons on the remote control, enter the three digits of the page number you wish to view. Alternatively, press the [] or [] buttons to view the previous or next page. After a short time it will appear on screen.



3. Enter more 3 digit page numbers as required.
4. Press the DIGITAL/□ button to exit Teletext.

How to use Teletext features

Feature	How to use
Hold	Some pages contain sub-pages which follow on automatically. This feature allows you hold the current page until you are ready to proceed. Press the []/[] button to hold the page currently being displayed. Press again to cancel.
Reveal	Some Teletext pages contain hidden information (e.g. for a quiz). Press the [] button to reveal the hidden information. Press again to cancel.
Mix	This feature allows you to superimpose Teletext on to the TV screen. Press the [] button to superimpose Teletext on to the TV screen. Press the [] button again to exit Teletext.
Fastext	Fastext allows you to access pages quickly and easily. When Fastext is available, four coloured items appear at the bottom of the screen. Press the corresponding coloured button on the remote control to access the required page.



The Digital EPG menu

The EPG menu (Electronic Programme Guide) provides you with a quick and easy way to:-

- a) View a complete list of the programmes available.
- b) Obtain a preview of the programmes currently being broadcast.
- c) Reduce the size of the list by selecting a category of programme, e.g. Sports or Movies.
- d) Record programmes.

1. The EPG menu is only available when watching Digital channels. If the TV is not already in Digital mode, press the DIGITAL/□ button on the remote control. Press the [] button on the remote control to display the EPG menu screen. This screen consists of an information window, a preview window, a 2 hour timer bar (divided into 30 minute intervals) and a 5 channel programme list covering the 2 hour period.



2. Press the [] or [] buttons to move the coloured cursor bar up or down the programme list and the [] or [] buttons to move left and right. If you press the [] button once more after highlighting the last programme on the right, the programmes scheduled for the next 2 hour period are displayed. As each programme is highlighted, a brief description of the programme appears in the event information box at the top left of the screen. If you do not wish to select a programme from the 5 channels listed, press the GREEN button to display the next 5 channels or RED button to display the previous 5 channels.

3. If a programme you highlight is currently being broadcast, press the OK button to obtain a preview in the preview window. If you have previously set a viewing age limit in the 'Digital Setting' menu, and the programme exceeds that age limit, you will be asked to enter your PIN code before the preview is allowed.
4. When the programme in the preview screen is the one you wish to watch, press the OK button to exit the EPG menu and view the programme at full size.

The Category pop-up list

The 'Category' pop-up list allows you to quickly search for a programme by choosing from different categories of programmes. For example, select the 'News' option from the 'Category' pop-up list to display programme information only for News channels.

1. With the EPG menu on screen, press the YELLOW button to display the 'Category' pop-up list.
2. Press the [] or [] buttons to highlight the category you want, then press the OK button. The EPG programme list will now only contain programmes of the type selected.



For information on the types of Categories along with instructions on how to add and remove programmes from the Favourite list, please refer to 'The Channel Index menu' section of this instruction manual.



The Digital INFO display

This menu gives you information on the programmes currently being shown as well as those programmes which are on next. When first selected, the 'Digital INFO display' gives a brief description of the current programme being transmitted, its channel number and the start and end time. The title of the next programme and its start and end time is also shown.

1. The 'Digital INFO display' is only available when watching Digital channels. If the TV is not already in Digital mode, press the DIGITAL/□ button on the remote control. Press the [i] button on the remote control to display the 'Digital INFO display' screen.



2. Press the ▲ button to obtain a brief description of the next programme in the schedule. If the programme box is blank, there is no information currently available. To return to the starting point, press the ▲ button repeatedly until the description for the current programme reappears.
3. Press the [i] button on the remote control at any time to exit the 'Digital INFO display'.

Note: To change channels while the 'Digital INFO display' is on screen, press the relevant numbered buttons on the remote control.

Using other INFO menu features

Subtitles

This feature will place Digital subtitles on the screen (similar to selecting p.888 in analogue Teletext mode).

With the 'Digital INFO display' on the TV screen, press the RED button to access the 'Subtitles' pop-up menu. Press the ▲ or ▼ button to highlight the language required then press OK to select.

To remove subtitles from the TV screen, access the 'Subtitles' pop-up menu and select 'Off'.

Audio

This feature allows you to listen to the broadcast in different languages*.

With the 'Digital INFO display' on the TV screen, press the GREEN button to access the 'Audio' pop-up menu. Press the ▲ or ▼ button to highlight the language required then press OK to select.

REC

This feature allows you to automatically set your VCR to record the selected programme**, or have the TV switch to the correct channel automatically when the selected programme starts.

With the 'Digital INFO display' on the TV screen, press the YELLOW button to access the 'REC' pop-up menu. If your VCR does not have Smartlink a message is displayed reminding you to manually set your VCR. Press the RED button to continue or press the BLUE button to return to the INFO display.

Notes: Do not switch off the TV once a programme has been set to record. If you do not wish to view the programme being recorded, press the TV I/O button on the remote control to switch the TV into standby mode.

When a programme has been set to record and the TV is in standby mode the standby indicator on the front of the TV will flash green periodically to inform you that a programme has been set to record.

Do not change channels or switch the TV to analogue mode once a programme has started recording or the recording will be cancelled.

Set-up

With the 'Digital INFO display' on the TV screen, press the BLUE button to access the 'Main Menu'. The 'Main Menu' is explained on the following pages.

Notes: *Only when the programme is broadcast in multiple languages.

Detail Set-up

The 'Detail Set-up' menu allows you to further customise your TV with the following features:

Manual Tuning

This feature allows you to select a channel number from the displayed list and change the digital services of that channel.

1. Press the [i] button on the remote control to display the 'Digital INFO display'. Press the BLUE button to display the 'Main Menu'.
2. Press the ▲ or ▼ button to highlight 'Detail Set-up' then press the OK button to display the 'Detail Set-up' menu.
3. Press the ▲ or ▼ button to highlight 'Manual Tuning' then press the OK button to display the 'Manual Tuning' menu.



4. Press the ▲ or ▼ button to highlight the chosen channel number for your new channel. If you do not wish to select any of the programme numbers listed, press the RED or GREEN button to display the previous or next 5 programme numbers on the list.
5. With your channel number highlighted, press the OK button to display the 'Manual Programme Search' screen.
6. Press the ▲ or ▼ button if you wish to change the channel number, then press the → button to make the select search box active.
7. Press the ▲ or ▼ button to begin the search process. The words 'Searching Down' or 'Searching Up' appear in the select search box to indicate that the TV is searching. If no Digital services are found on the channel you have chosen, the channel number changes up or down automatically and the search continues. When all services allocated to the selected channel have been found, the service selection screen is displayed.
8. Press the ▲ or ▼ button to find and highlight the service you wish to allocate to the channel number selected in Step 4, then press the OK button to display the channel selection screen.
9. Repeat Steps 4 to 8 if you wish to manually add more channels to your TV.
10. Press the BLUE button on the remote control three times to remove the 'Digital INFO display' from the TV screen.

PIN Code

This feature allows you to set a 4-digit PIN code.

1. Press the [i] button on the remote control to display the 'Digital INFO display'. Press the BLUE button to display the 'Main Menu'.
2. Press the ▲ or ▼ button to highlight 'Detail Set-up' then press the OK button to display the 'Detail Set-up' menu.
3. Press the ▲ or ▼ button to highlight 'PIN Code' then press the OK button to display the 'PIN Code' menu.







4. Enter your PIN code using the numbered buttons on the remote control. If you enter a wrong number, press the RED button to clear and start again.
5. Once you have entered a 4-digit code a cursor will appear in the second PIN Code box. Enter your new PIN code once again as confirmation. Press the OK button to confirm.
6. When both PIN codes match, a message appears to inform you that your new PIN code has been accepted. This is the PIN code you must use in future.
7. Press the BLUE button on the remote control to remove the 'Digital INFO display' from the TV screen.





Advanced Operation

Software Download

Periodically Sony issues updates for the software that controls your TV. This feature allows you to automatically receive updates free through your existing aerial.





1. Press the  button on the remote control to display the 'Digital INFO display'. Press the BLUE button to display the 'Main Menu'.
2. Press the  or  button to highlight 'Detail Set-up' then press the OK button to display the 'Detail Set-up' menu.
3. Press the  or  button to highlight 'Software Download' then press the OK button to display the 'Software Download' menu.



4. Press the  or  button to change the 'Current Setting'. If you wish to receive downloads, the 'Current Setting' should be set to 'On'. If you do not wish to receive downloads, the 'Current Setting' should be set to 'Off'.
5. Press the OK button to confirm.
6. Press the BLUE button to return to the Main menu.
7. Press the BLUE button on the remote control to remove the 'Digital INFO display' from the TV screen.

System Information

This is an information screen only. It tells you the current version of the software in your TV together with the signal strength, as indicated by the red bar in the display.

1. Press the  button on the remote control to display the 'Digital INFO display'. Press the BLUE button to display the 'Main Menu'.
2. Press the  or  button to highlight 'Detail Set-up' then press the OK button to display the 'Detail Set-up' menu.
3. Press the  or  button to highlight 'System Information' then press the OK button to display the 'System Information' menu.



4. Press the BLUE button to return to the Main menu.
5. Press the BLUE button on the remote control to remove the 'Digital INFO display' from the TV screen.

Advanced Operation





The TV menu system

This TV contains a menu system which is based on a series of user friendly on-screen displays. These displays will help you to get the most from your TV, helping you to change the picture settings, sound settings and change the order of the TV channels.

The Picture Adjustment menu

1. Press the MENU button to display the main menu, then press the  button to enter the 'Picture Adjustment' menu.



2. 'Mode:' is highlighted. Press the  or  button to highlight one of the options, then after pressing the  button to activate the option press  and  buttons to adjust the setting.
3. Press the OK button to store the new setting and repeat step 2 to adjust the other options. The Mode option has three settings for you to choose from:-

Personal: This setting allows you to adjust the Brightness, Colour, Contrast and Sharpness levels to suit your personal preference.



Live: This is a fixed setting and is recommended for live broadcasts.

Movie: This is a fixed setting and is recommended for watching films.





4. Press the MENU button to return to normal TV operation.

Note: Highlight Reset and press OK only if you wish to return the picture to the factory preset levels.

The Sound Adjustment menu

1. Press the MENU button to display the main menu, then press the  button to highlight the  symbol. Now press the  button to enter the 'Sound Adjustment' menu.



2. 'Mode:' is highlighted. Press the  or  button to highlight one of the options, then after pressing the  button to activate the option press  and  buttons to adjust the setting.
3. Press the OK button to store the new setting and repeat step 2 to adjust the other options. The Mode option has four settings for you to choose from:-

Personal: This setting allows you to adjust all the available options in the 'Sound adjustment' menu to suit your personal preference.

Rock: This is a fixed setting and is recommended for rock soundtracks.

Pop: This is a fixed setting and is recommended for pop soundtracks.

Jazz: This is a fixed setting and is recommended for jazz soundtracks.

Note: 'Treble' and 'Bass' settings can only be altered when the 'Mode' option is set to Personal.

4. When 'Detail Adjustment' is highlighted, press the  button to display the 'Detail Adjustment' sub menu. This menu gives you a further three options to choose from.

continued...

Advanced Operation

- Highlight and activate one of the options using the \blacktriangle and \blacktriangleright buttons, then press the \blacktriangle or \blacktriangleright buttons to set the option to On or Off. See the table below for an explanation of each option and their effects.
- Press the OK button to store the new setting, then repeat step 5 to alter the other options.
- Press MENU button to return to normal TV operation.

Dolby® Virtual	When set to 'On', the TV simulates the effects of Dolby Pro Logic Surround sound. Note: If you connect headphones to this TV or if you set the 'Auto Volume' option to 'On', 'Dolby Virtual' will automatically be set to Off.
Auto Volume	When set to 'On', the volume level will remain constant even if the broadcast level should change, i.e. during commercial breaks. Note: This option automatically sets itself to 'Off' when 'Dolby Virtual' is set to 'On'.
TV Speakers	Set to 'Off' if you wish to connect an external amplifier to the audio output sockets on the rear of the TV.

Notes on the Sound Adjustment menu

- Highlight 'Reset' and press OK only if you wish to return the sound settings to their factory preset levels.
- When receiving a bilingual broadcast set the 'Dual Sound' option to 'A' for channel 1 sound, 'B' for channel 2 sound or 'Mono' if the mono channel is available for selection. When receiving a stereo broadcast the 'Dual Sound' option can be set to Stereo or Mono.
- This TV has been designed to create a Virtual Dolby Surround sound effect from a 'Dolby Pro Logic Surround' broadcast without the need for additional speakers. However, you can connect an external amplifier to this TV if desired (see 'Connecting additional equipment' section of this manual).
- Manufactured under licence from Dolby Laboratories. 'Dolby', 'Pro Logic' and the double-D symbol are trademarks of Dolby Laboratories.

The Timer menu

The 'Sleep Timer' allows you to select a period of time after which the TV automatically switches itself into standby mode.

- Press the MENU button to display the main menu. Use the \blacktriangle or \blacktriangleright button to highlight the ⌚ symbol. Press the \blacktriangleright button twice to highlight 'Off' in the 'SleepTimer' menu.



- Press the \blacktriangle or \blacktriangleright buttons to set the amount of time before the TV switches itself into standby. This can be in 15 minute intervals up to a maximum of 4 hours.
- Press the OK button to store.
- Press the MENU button to return to normal TV operation. One minute before the TV switches into standby, the time remaining is counted down on screen.

Note: In analogue mode you can check the time remaining until standby by pressing the ⌚ button. The time remaining is displayed in the bottom left corner of the TV screen.

Advanced Operation

The Set Up menu

The 'Set Up' menu contains many features that enable you to customise your TV. The following pages explain all of the features contained in the 'Set Up' menu.

Auto Tuning

The TV automatically tuned in all the available channels when you first installed the TV. Follow these instructions if you wish to re-install your TV at an alternative location or search for new channels that have been subsequently launched by broadcasters.

- With the TV in analogue mode, press the MENU button to display the main menu. Press the \blacktriangle or \blacktriangleright button to highlight the ⌚ symbol, then press the \blacktriangleright button to enter the 'Set Up' menu.



- Press the \blacktriangle or \blacktriangleright buttons to highlight 'Auto Tuning' then press the \blacktriangleright button to confirm. The autotune prompt display appears on screen.



- Press the OK button to select 'Yes' and begin the autotune procedure. Whilst tuning is taking place, the search and store display appears on screen. When all available signals have been captured and stored, the display is removed and the TV returns to normal operation.

Notes: You can cancel the tuning at any time by pressing the MENU button.

Programme Sorting

You can use this feature to change the order in which the analogue channels are stored on your TV.

- With the TV in analogue mode, press the MENU button to display the main menu. Press the \blacktriangle or \blacktriangleright button to highlight the ⌚ symbol, then press the \blacktriangleright button to enter the 'Set Up' menu.



- Press the \blacktriangle or \blacktriangleright buttons to highlight 'Programme Sorting' then press the \blacktriangleright button to display the Programme Sorting menu on screen.



- Press the \blacktriangle or \blacktriangleright button to highlight the channel you wish to move to a new position, then press the OK button.
- Press the \blacktriangle or \blacktriangleright button to highlight the new channel number for your channel, then press the OK button.
- Repeat steps 3 and 4 to move other channels if required, then press the MENU button to return to normal TV operation.

Additional Information

Remote control of connected equipment

This remote control can operate not only Sony DVDs and VCRs, but also those made by other manufacturers. The following instructions will guide you through the set up procedure.

1. Find the 3 digit code for your brand from the list below.
2. Press the Media Select button on the remote control until either the green VCR light is illuminated **OR** the green DVD light is illuminated.
3. Whilst the required green light is illuminated, press and hold down the YELLOW button for approximately 6 seconds, until the light starts to flash.
4. Use the numbered buttons to enter the 3 digit code for your DVD or VCR. Once a correct number has been entered, all three green lights will illuminate momentarily.
5. Turn on your DVD or VCR and check that the remote control operates the main functions. If not, repeat steps 2 - 4 and enter the next 3 digit code allocated to your brand of VCR or DVD.
6. When you wish to use the remote control to operate the TV again, press the Media Select button until the TV green light illuminates. Don't forget to select VCR or DVD using the Media Select button every time you wish to operate that equipment with this remote control.

Note: The brand codes you set may be lost if weak batteries are not replaced immediately. Should this happen, use the above procedure to re-enter the code. A small label has been attached to the inside of the battery cover for you to make a note of your brand codes. Not all brands and models of DVDs or VCRs are covered in this list, however, Sony will endeavour to update the software periodically. Please refer to the code table provided with your remote control.



VCR Brand List		DVD Brand List	
Brand	Code	Brand	Code
SONY (VHS)	301, 302, 303, 309	SONY	001
SONY (BETA)	303, 307, 310	AIWA	021
SONY (DVD)	304, 305, 306	DENON	018, 027, 020, 002
AIWA	325, 331, 351	GRUNDIG	009, 028, 023, 024, 016, 003
AKAI	326, 329, 330	HITACHI	025, 026, 015, 004
DAEWOO	342, 343	JVC	006, 017
GRUNDIG	358, 355, 360, 361, 320, 351	KENWOOD	008
HITACHI	327, 333, 334	LG	015, 014
JVC	314, 315, 322, 344, 352, 353, 354, 348, 349	LOEWE	009, 028, 023, 024, 016, 003
LG	332, 338	MATSUI	013, 016
LOEWE	358, 355, 360, 361, 320, 351	ONKYO	022
MATSUI	356, 357	PANASONIC	018, 027, 020, 002
ORION	328	PHILIPS	009, 028, 023, 024, 016, 003
PANASONIC	321, 323	PIONEER	004
PHILIPS	311, 312, 313, 316, 317, 318, 358, 359	SAMSUNG	11, 14
SAMSUNG	339, 340, 341, 345	SANYO	007
SANYO	335, 336	SHARP	019, 027
SHARP	324	THOMSON	012
THOMSON	319, 350	TOSHIBA	003
TOSHIBA	337	YAMAHA	018, 027, 020, 002

Additional Information

Troubleshooting

Here are some simple solutions to problems which may affect the picture and sound.

Problem	Cause
No picture, no sound.	<ul style="list-style-type: none"> • Power off. • TV in standby. • Aerial disconnected. • Picture preset level adjustment. • No digital transmissions in your area. • No digital transmissions from the transmitter you are currently using. • Weak signal. • Unsuitable aerial. • Scrambled/subscription-only channel. • Programme used only for data (no picture or sound). • Programme not being transmitted. • Digital mode Timer Record active (regular flash). • Fault (irregular flash). • Volume control. • TV speakers turned off. • Headphones are connected. • Wrong external mode selected on an RGB video source. • Colour level setting. • Batteries low. Media Selector set to wrong mode for the equipment in use. • Inputs from external equipment not switched off.
Poor or no picture (screen is dark), but good sound. No Digital channels after tuning.	
Some channels are blank.	
Standby indicator flashing.	
Good Picture, no sound.	
Poor picture quality. No colour on colour programmes. Remote control does not function.	
Distorted picture when changing programmes or selecting Teletext.	
Cause	Solution
TV in standby.	<ul style="list-style-type: none"> • Plug in the TV. • Press the button on the front of the TV. • If the indicator is on press the button or a numbered button on the remote control. • Check the aerial connection. • Select on the TV menu system then adjust the brightness, picture and colour balance levels. • Contact a local installer to find out when digital transmissions begin in your area. • Contact a local installer to find out at which transmitter you should be pointing your aerial. • Change your aerial to cover the channels used by digital programmes. (Contact a local installer) • Ensure aerial is correctly aligned to transmitter. • Ensure aerial is plugged directly into the TV (not through other equipment). • Upgrade to a higher gain aerial. • Subscribe to pay-per-view broadcaster. • See 'Skipping a programme' section of this manual. • See 'Programme Sorting' section of this manual. • Do not open the cabinet, refer to qualified personnel. • Contact your nearest Sony Service Centre. • Press the + button on the remote control. • Refer to 'The Sound menu' section in this manual • If is displayed on the screen, press the button on the remote control. • Disconnect headphones. • Press the button repeatedly until the RGB symbol is displayed on screen. • Select on the TV menu system then adjust the colour setting.
Aerial disconnected. Picture level adjustment.	
No Digital transmissions in your area.	
No Digital transmissions from the transmitter you are currently using. Unsuitable aerial.	
Weak signal.	
Scrambled/subscription-only channel. Programme information without picture or sound.	
Fault.	
Volume control. TV speakers turned off	
Wrong external mode selected.	
Colour level setting.	

- If you continue to have these problems, have your TV serviced by qualified personnel or you can contact the Sony UK Digital HelpLine on 0870 600 1717.
- NEVER open the casing yourself.

SECTION 2 DISASSEMBLY

2-1. Rear Cover Removal

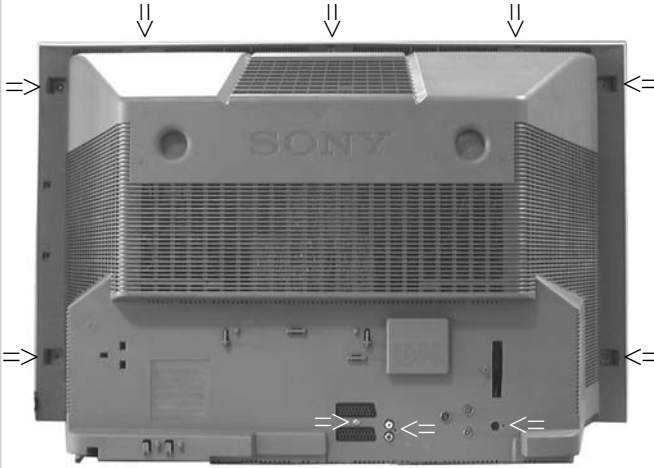

Remove the rear cover fixing screws indicated and withdraw the rear cover from the beznet.

2-2. Side Control Module Removal

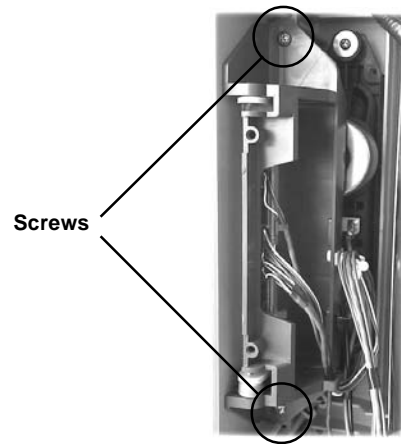

Remove the two screws fixing the user control module to the side of the set. The control module can then be removed by sliding it towards the rear of the set allowing access to the H2 Board.

2-3. Chassis Removal and Refitting

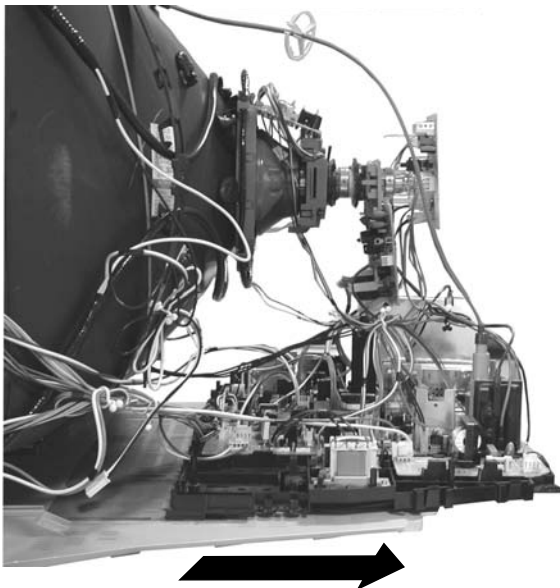

To remove lift the main bracket rear slightly and slide the chassis away from the beznet. Ensure that the interconnecting leads are released from their purse locks to prevent damage being caused.

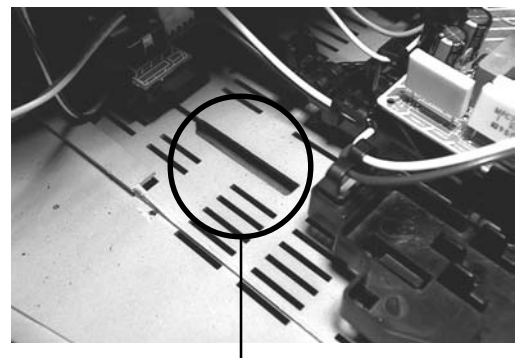

When refitting the chassis ensure that the main bracket is located in the beznet guide slots before sliding the chassis forwards. Refit the interconnecting leads in their respective purse locks.

2-4. Service Position

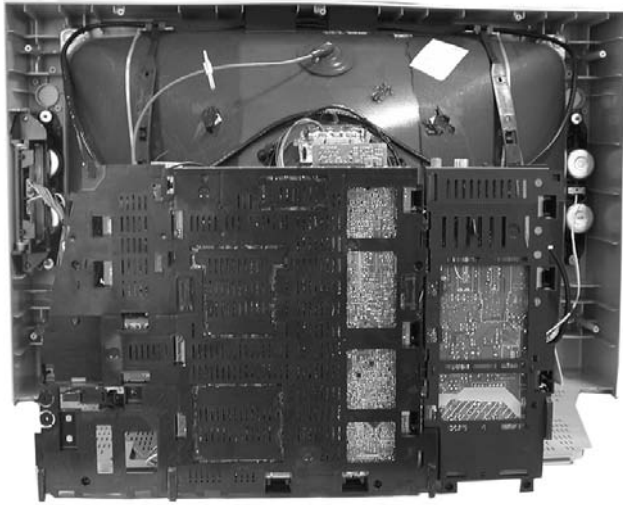

Position the chassis as indicated to access the solder side of the PWB's. To gain access to the A Board follow the instructions on page 16. [Removal and Replacement of the main bracket bottom plates].

2-5. F6 and H8 Board Removal

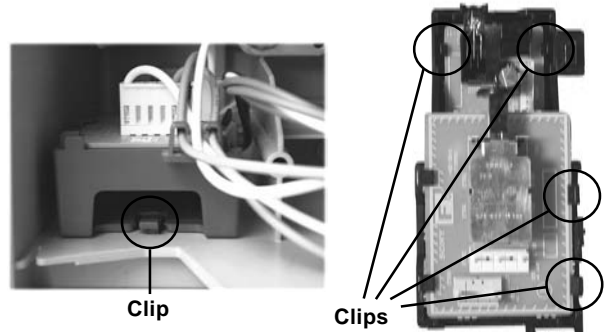

Release the clip circled and pull the F6 bracket towards the rear of the set. The bracket can then be removed to allow access to the boards.
To remove the F6 and H8 Boards release the clips circled and ease the boards gently away from the support bracket.

2-6. N Board Removal

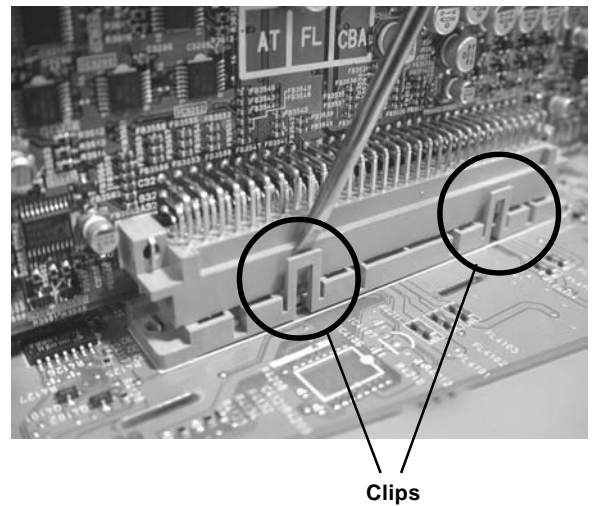
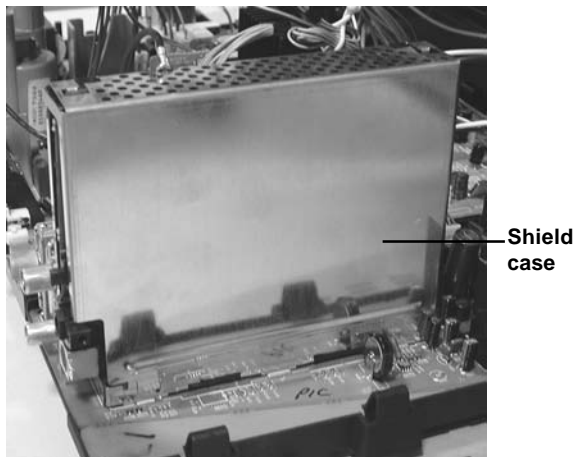

Remove the shield case by pulling vertically until it is clear of the N Board. Release the N board socket retaining clips, circled, by gently prising them with a screwdriver and carefully lift the N Board vertically.

2-7. Picture Tube Removal

WARNING: BEFORE REMOVING THE ANODE CAP

High voltage remains in the CRT even after the power is disconnected. To avoid electric shock, discharge CRT **before** attempting to remove the anode cap. Short between anode and CRT coated earth ground strap.

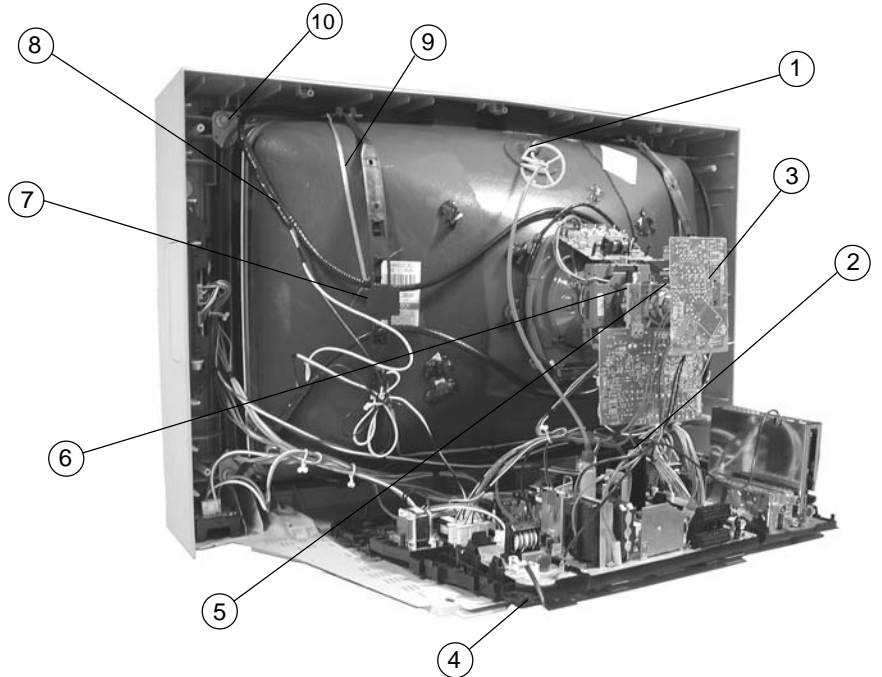
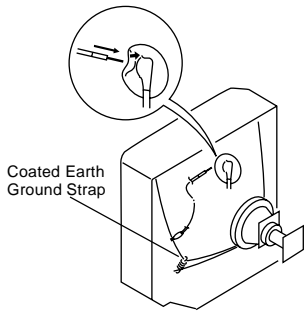

1. Discharge the anode of the CRT and remove the anode cap.
2. Unplug all interconnecting leads from the Deflection yoke, neck assy, degaussing coils and CRT grounding strap.
3. Remove the C Board from the CRT.
4. Remove the chassis assembly.
5. Loosen the Neck assembly fixing screw and remove.
6. Loosen the Deflection yoke fixing screw and remove.
7. Place the set with the CRT face down on a cushion and remove the Degaussing Coil holders.
8. Remove the Degaussing Coils.
9. Remove the CRT grounding strap and spring tentioners.
10. Unscrew the four CRT fixing screws [located on each CRT corner] and remove the CRT.
[Take care not to handle the CRT by the neck.]

Removal of the Anode-Cap

* REMOVING PROCEDURES.

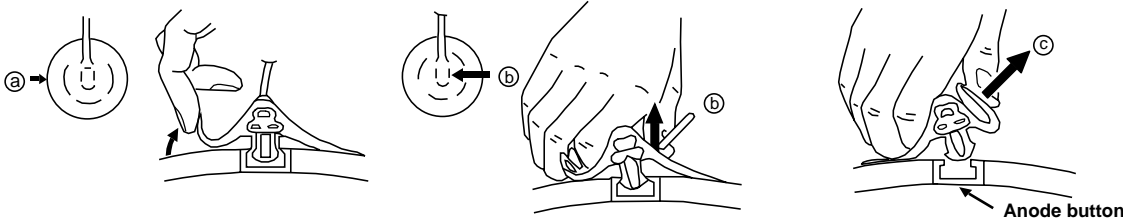

- ① Turn up one side of the rubber cap in the direction indicated by the arrow (a)
- ② Using a thumb pull up the rubber cap firmly in the direction indicated by the arrow (b)
- ③ When one side of the rubber cap is separated from the anode button, the anode-cap can be removed by turning up the rubber cap and pulling it up in the direction of the arrow (c)

How to handle the Anode-Cap

1. To prevent damaging the surface of the anode-cap do not use sharp materials.
2. Do not apply too great a pressure on the rubber, as this may cause damage to the anode connector.
3. A metal fitting called a shatter hook terminal is fitted inside the rubber cap.
4. Do not turn the rubber foot over excessively, this may cause damage if the shatter hook sticks out.

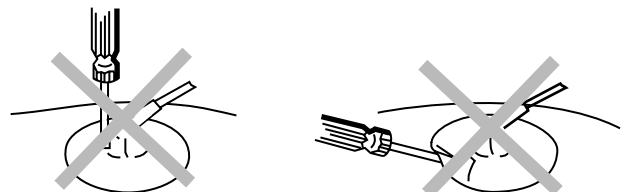

REMOVAL AND REPLACEMENT OF THE MAIN-BRACKET BOTTOM PLATES.

(1) REMOVING THE PLATES

In the event of servicing being required to the solder side of the D Board printed wiring board, the bottom plates fitted to the main chassis bracket require to be removed.

This is performed by cutting the gates with a sharp wire cutter at the locations indicated by the arrows.

Note : There are 3 plates fitted to the main bracket and secured by 3 gates.
Only remove the necessary plate to gain access to the printed wiring board.

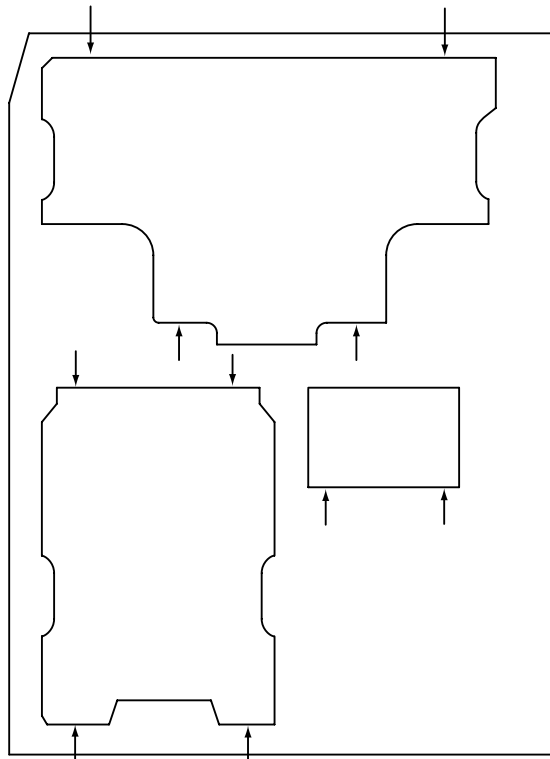

For safety reasons, on no account should the plates be removed and not refitted after servicing.

(2) REFITTING THE PLATES

Because the plates differ in size it is important that the correct plates are refitted in their original location.

Please note that the plates need to be rotated 180 degrees from their cut position to allow the tabs to be fitted into their catch positions.

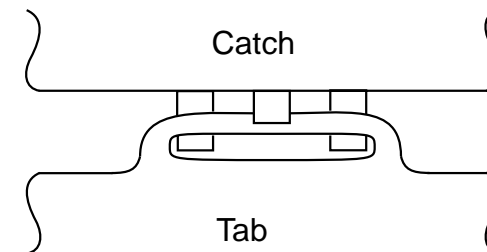

SECTION 3 SET-UP ADJUSTMENTS

- When complete readjustment is necessary or a new picture tube is installed, carry out the following adjustments.
- Unless there are specific instructions to the contrary, carry out these adjustments with the rated power supply.
- Unless there are specific instructions to the contrary, set the controls and switches to the following settings :

Contrast 80% [or remote control normal]

Brightness 50%

Carry out the adjustments in the following order :

- 3-1. Beam Landing.
- 3-2. Convergence.
- 3-3. Focus.
- 3-4. White Balance.

Note : Test equipment required.

1. Color bar/pattern generator.
2. Degausser.
3. Oscilloscope.
4. Digital multimeter.

Preparation:

1. In order to reduce the influence of geomagnetism on the set's picture tube, face it in an easterly or westerly direction.
2. Switch on the set's power and degauss with the degausser.

3-1. Beam Landing

1. Input an all white signal from the pattern generator. Set the Contrast and Brightness to normal.
2. Set the pattern generator raster signal to Red.
3. Move the deflection yoke forward and adjust with the purity control so that the Red is at the centre and the Blue and Green take up equally sized areas on each side of the screen. [See Fig.3-1 - 3-3].
4. Move the deflection yoke backwards and adjust so that the entire screen becomes Red. [See Fig.3-1]
5. Switch the raster signal to Blue, then to Green and verify the condition.
6. When the position of the deflection yoke has been determined, fasten the deflection yoke with the screws.
7. If the beam does not land correctly in all the corners, use a magnet to correct it. [See Fig.3-4]

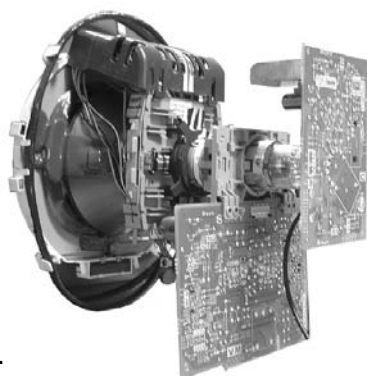

Fig. 3-1.



Caution :

High voltages are present on the Deflection yoke terminals - take care when handling the Deflection yoke whilst carrying out adjustments.

Fig. 3-2.

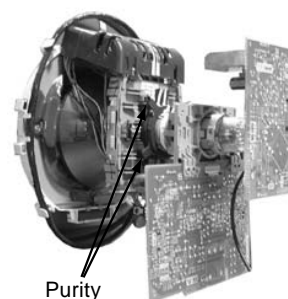

Fig. 3-3.

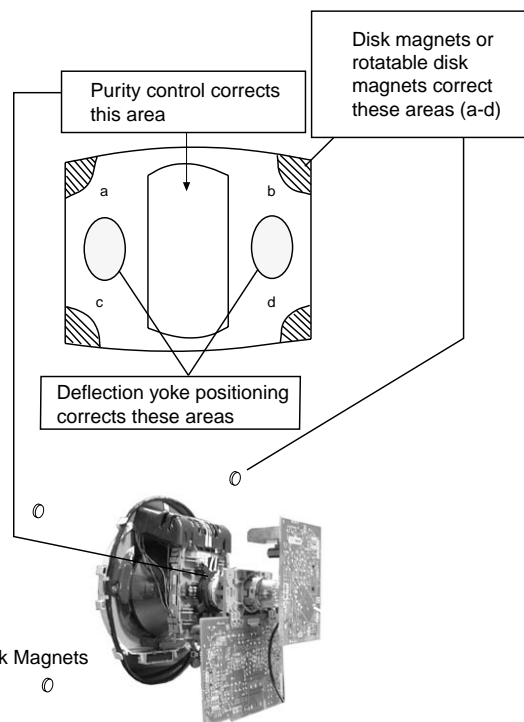
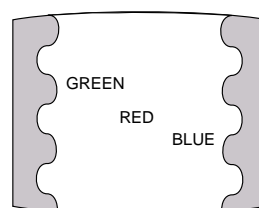

Fig.3-4

3-2. Convergence

Preparation:

- Before starting this adjustment, adjust the focus, horizontal size and vertical size.
- Minimize the Brightness setting.
- Input a dot pattern from the pattern generator.

Horizontal and Vertical Static Convergence

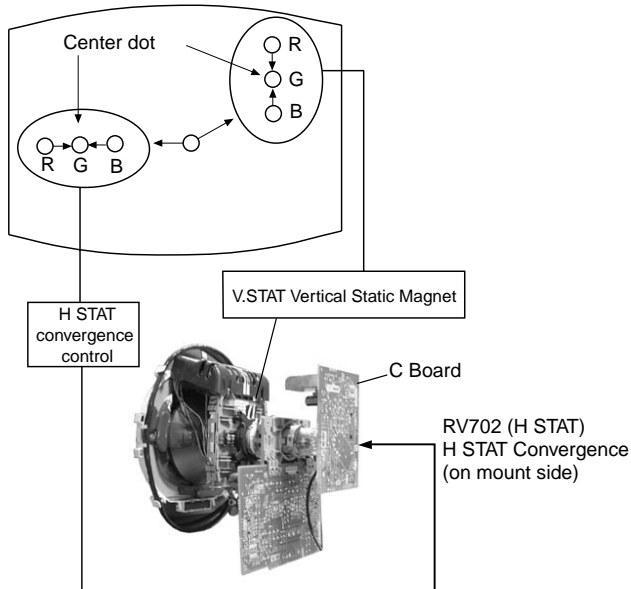
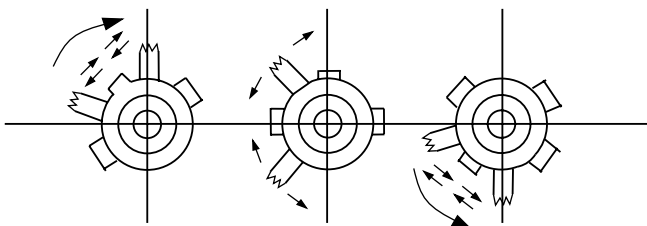

Fig.3-5

1. [Moving horizontally], adjust the H.STAT control so that the Red, Green and Blue points are on top of each other at the centre of the screen.
2. [Moving vertically], adjust the V.STAT magnet so that the Red, Green and Blue points are on top of each other at the centre of the screen.
3. If the H.STAT variable resistor is unable to bring the Red, Green and Blue points together at the centre of the screen, adjust the horizontal convergence with the H.STAT variable resistor and the V.STAT magnet in the manner indicated below.

[In this case, the H.STAT variable resistor and the V.STAT magnet influence each other].

- Tilt the V.STAT magnet and adjust the static convergence by opening or closing the V.STAT magnet.



4. If the V.STAT magnet is moved in the direction of the (a) and (b) arrows, the Red, Green and Blue points move as indicated below.

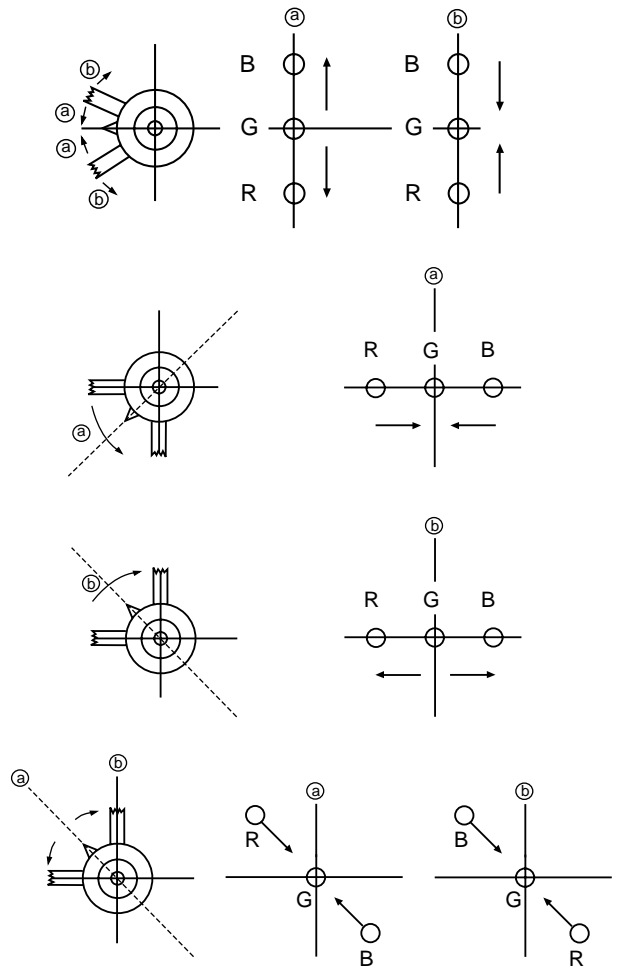

Operation of the BMC (Hexapole) magnet.

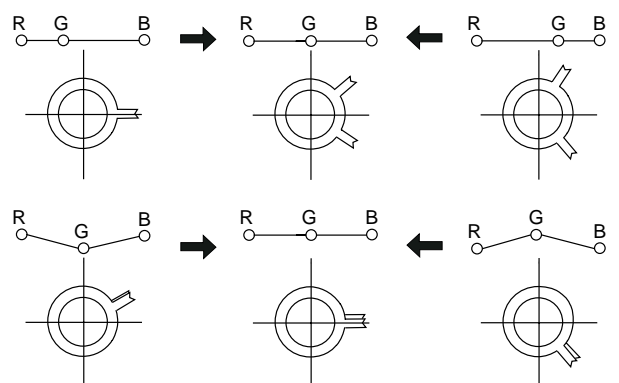

The movement of the magnets interact with each other and so the respective dot position should be monitored while carrying out this adjustment.

Use the H.STAT VR to adjust the Red, Green and Blue dots so that they coincide at the centre of the screen (by moving the dots in the horizontal direction).

Geometry Adjustment.

Preparation:

Before starting this adjustment, adjust the horizontal and vertical static convergence.

1. Remove the deflection yoke spacer.
2. Tilt the deflection yoke as indicated in the figure below and optimise the geometry.
Tilting the DY Up and Down will balance the upper and lower pin adjustment.
Tilting the DY Left and Right will balance the H-Trap adjustment.
3. Re-install the deflection yoke spacer.

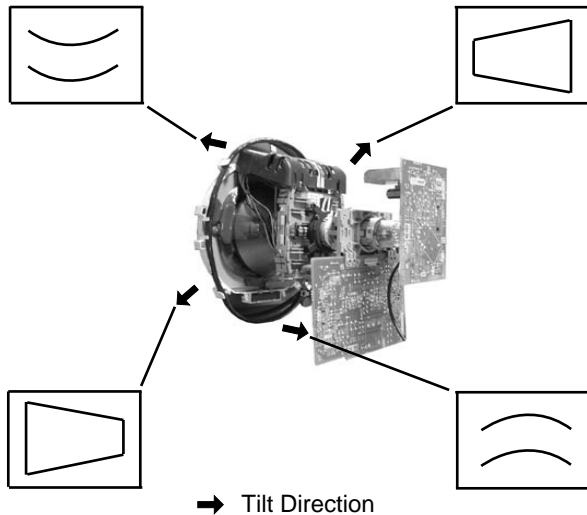

YCH Adjustment

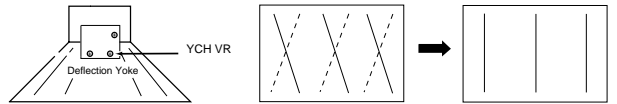

TLV Adjustment

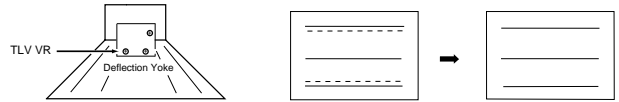

Screen Corner Convergence

If you are unable to adjust the corner convergence properly, this can be corrected with the use of permalloy magnets.

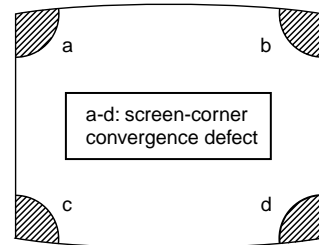

HTIL Adjustment

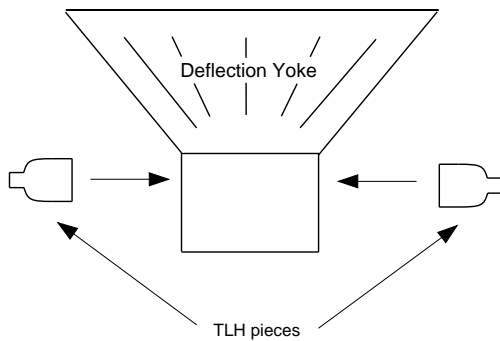

HTIL correction can be performed by adding a TLH correction assembly to the Deflection yoke.

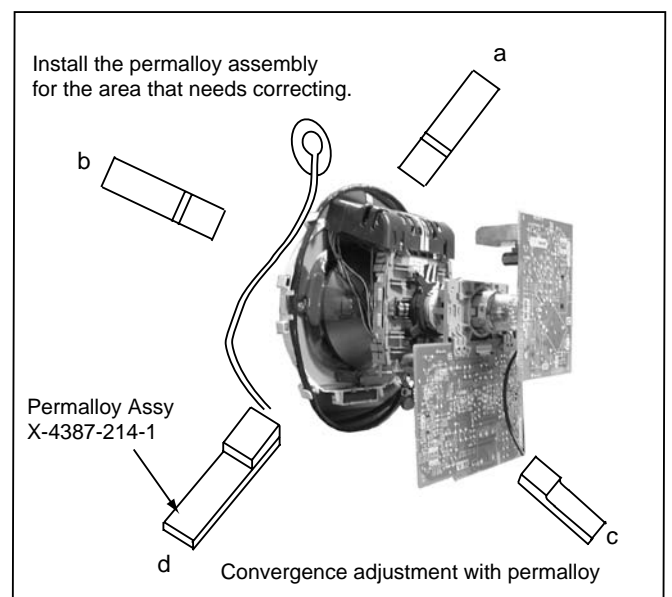
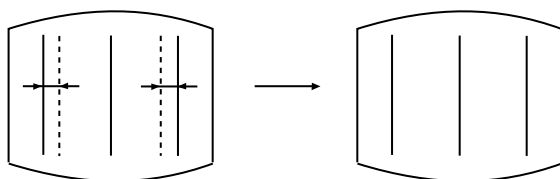

Layout of each control

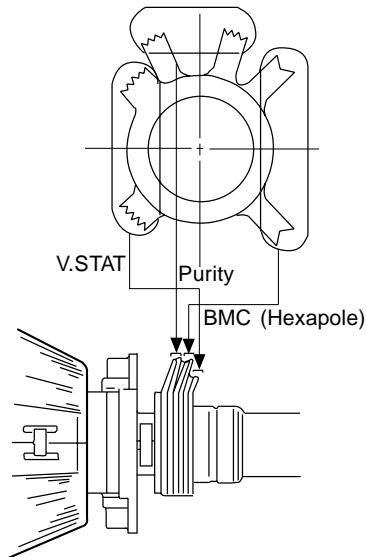

3-3. Focus Adjustment

1. Receive a television broadcast signal.
2. Normalize the picture setting.
3. Adjust the focus control located on the flyback transformer to obtain the best focus at the centre of the screen.
Bring only the centre area of the screen into focus, the magenta-ring appears on the screen. In this case, adjust the focus to optimize the screen uniformly.

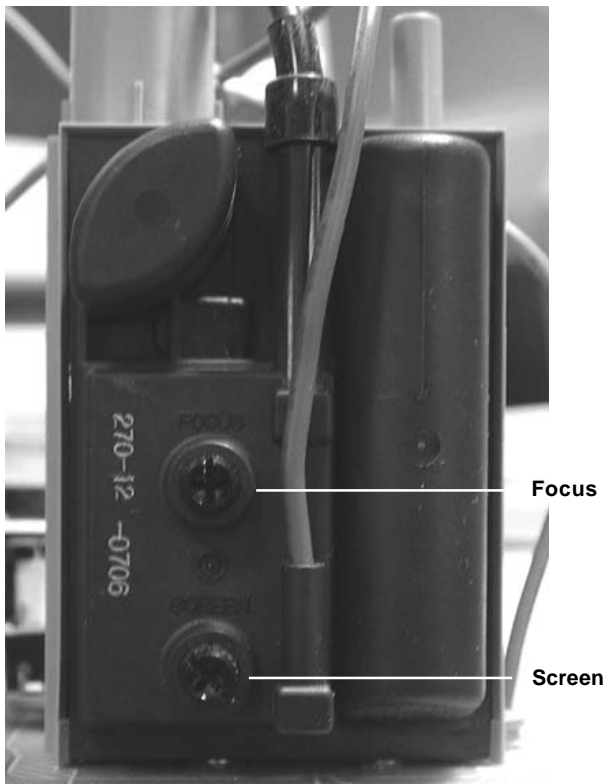

3-4. Screen (G2), White Balance

[Adjustment in the service mode using the remote commander]

G2 adjustment

1. Input a dot signal from the pattern generator.
2. Enter the 'Service Mode' by pressing 'TEST', 'TEST' and '38' (TT-38) on the remote commander, to set up the G2 service adjustment mode.
3. Whilst watching the picture, adjust the G2 control [SCREEN] located on the Flyback Transformer to the point where the OSD menu indication shows "OK".

White balance adjustment for TV mode

1. Input an all-white signal from the pattern generator.
2. Enter into the 'Service Mode' by pressing 'TEST', 'TEST' and 'MENU' on the Service Commander.
3. Select 'Service' from the on screen menu display and press the right arrow button on the remote commander.
4. The 'Service' menu will appear on the screen.
[See Page 21]
5. Set the 'Contrast' to MAX.
6. Set the 'R-Drive' to 25.
7. Adjust the 'G-Drive' and the 'B-Drive' so that the white balance becomes optimum.
8. Press the 'OK' button to write the data for each item.
9. Set the 'Contrast' to MIN.
10. Adjust the 'G-Cutoff', and the 'R-Cutoff' with the left and right buttons on the remote commander so that the white balance becomes optimum.
11. Press the 'OK' button to write the data for each item.

SECTION 4 CIRCUIT ADJUSTMENTS

4-1. Electrical Adjustments

Service adjustments to this model can be performed using the supplied remote Commander RM-932.

How to enter into the Service Mode

1. Turn on the main power switch and enter into the stand-by mode.
2. Press the following sequence of buttons on the Remote Commander.

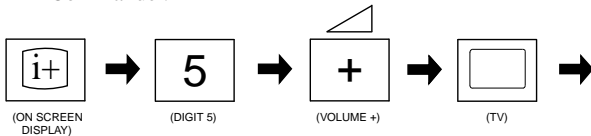

'TT—' will appear in the upper right corner of the screen.
Other status information will also be displayed.

3. Press 'MENU' on the remote commander to obtain the following menu on the screen.

Geometry	
Service	
Design	
Status	
Sound	
IF adjust	
Error Menu	
FE-2 Digital v0.03	
Factory data FFh FFh	
MSP Device : MSP3411G	

4. Move to the corresponding adjustment item using the up or down arrow buttons on the Remote Commander.
5. Press the right arrow button to enter into the required menu item.
6. Press the 'Menu' button on the Remote Commander to quit the Service Mode when all adjustments have been completed.

Note :

- Before performing any adjustments ensure that the correct model has been selected in the 'Model Setting' menu.
- After carrying out the service adjustments, to prevent the customer accessing the 'Service Menu' switch the TV set OFF and then ON.

ERROR MENU

E02	OCP	(0, 255)	0
E03	OVP N/A	(0, 255)	0
E04	VSYNC	(0, 255)	0
E05	IKR	(0, 255)	0
E06	IIC	(0, 255)	0
E07	NVM	(0, 255)	0
E08	JUNGLE	(0, 255)	0
E09	TUNER	(0, 255)	0
E10	SOUNDP	(0, 255)	0
E11	8V	(0, 255)	0

WORKING TIME

HOURS	2
MINUTES	11

SERVICE

Offset-R	(0, 63)	Adj
Offset-G	(0, 63)	Adj
R-Drive	(0, 63)	31
G-Drive	(0, 63)	Adj
B-Drive	(0, 63)	Adj
Peak-Freq	(0, 3)	0
Luma-Delay	(0, 15)	8
SC0	(0, 3)	3
White-Peak	(0, 15)	15
Subcont	(0, 15)	8
Subright	(0, 63)	30
Subcol	(0, 63)	Adj
Subsharp	(0, 63)	25
Cutoff Br.	(0, 63)	31
Br OSD	(0, 15)	10
Br TXT	(0, 15)	7

GEOMETRY

V-Linearity	(0, 63)	Adj
V-Scroll	(0, 63)	32
Left-HBlk	(0, 15)	10
Right-HBlk	(0, 15)	7
V-Angle	(0, 63)	Adj
V-Bow	(0, 63)	Adj
H-Centre	(0, 63)	Adj
H-Size	(0, 63)	Adj
Pin-Amp	(0, 63)	Adj
U-Corner-Pin	(0, 63)	Adj
L-Corner-Pin	(0, 63)	Adj
Pin Phase	(0, 63)	Adj
V-Slope	(0, 63)	40
V-Size	(0, 63)	Adj
S-Correction	(0, 63)	Adj
V-Centre	(0, 63)	Adj
V-Zoom	(0, 63)	27
Magenta	(0, 63)	31

IF ADJUST

AGC Adjust	(-16, +15)	+0
Automute		1
Audio Gain		0
L Gating		0

Sub Brightness Adjustment

1. Input a Monoscope pattern.
2. Press 'TEST' 'TEST' 13 on the Remote Commander.
3. Adjust the 'Sub-Brightness' data so that there is barely a difference between the 0 IRE and 10 IRE signal levels.

Sub Contrast Adjustment

1. Input a video signal that contains a small 100% white area on a black background.
2. Connect an digital voltmeter to Pin 10 of J701 [C Board].
3. Adjust the Sub-Contrast ['TT11'] to obtain a voltage of 105 +/- 5V.

Sub Colour Adjustment

1. Receive a PAL colour bar signal.
2. Connect an oscilloscope to Pin 5 of CN003 [A Board].
3. Enter into the 'Service' service menu.
4. Adjust the 'Sub Colour' data so that the Cyan, Magenta and Blue colour bars are of equal levels as indicated below.

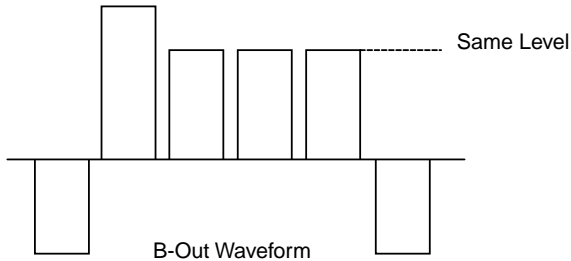

Tuner AGC Adjustment

Note:

There should be no need to adjust the AGC as this is pre-adjusted during manufacture of the FRONTEND. If the AGC does need adjustment then follow steps 1. to 4. below.

1. Receive a signal of 62dBuV / 75 ohm terminated via the tuner antenna socket.
2. Connect a voltmeter to pin1 of TU101 [print side of A1 Board] or to the AGC pin of CN301 [mount side of A Board].
3. Confirm that the AGC voltage is 3.5volts +/- 0.3volts.
4. If adjustment is required, then re-adjust the AGC variable resistor (located at the top rear of the FRONTEND) to obtain a voltage of 3.5V +/- 0.3V.

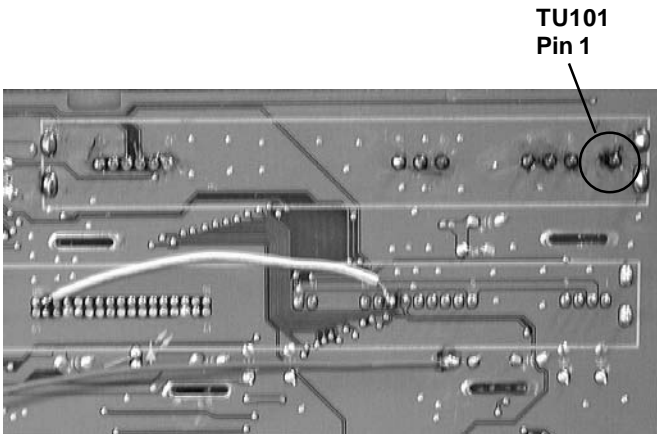

[Print side of A1 board]

Deflection System Adjustment

1. Enter into the 'Geometry' service menu.
2. Select and adjust each item in order to obtain the optimum image.

GEOMETRY		
V-Linearity	(0, 63)	Adj
V-Scroll	(0, 63)	32
Left-HBlk	(0, 15)	10
Right-HBlk	(0, 15)	7
V-Angle	(0, 63)	Adj
V-Bow	(0, 63)	Adj
H-Centre	(0, 63)	Adj
H-Size	(0, 63)	Adj
Pin-Amp	(0, 63)	Adj
U-Corner-Pin	(0, 63)	Adj
L-Corner-Pin	(0, 63)	Adj
Pin Phase	(0, 63)	Adj
V-Slope	(0, 63)	40
V-Size	(0, 63)	Adj
S-Correction	(0, 63)	Adj
V-Centre	(0, 63)	Adj
V-Zoom	(0, 63)	27
Magenta	(0, 63)	31

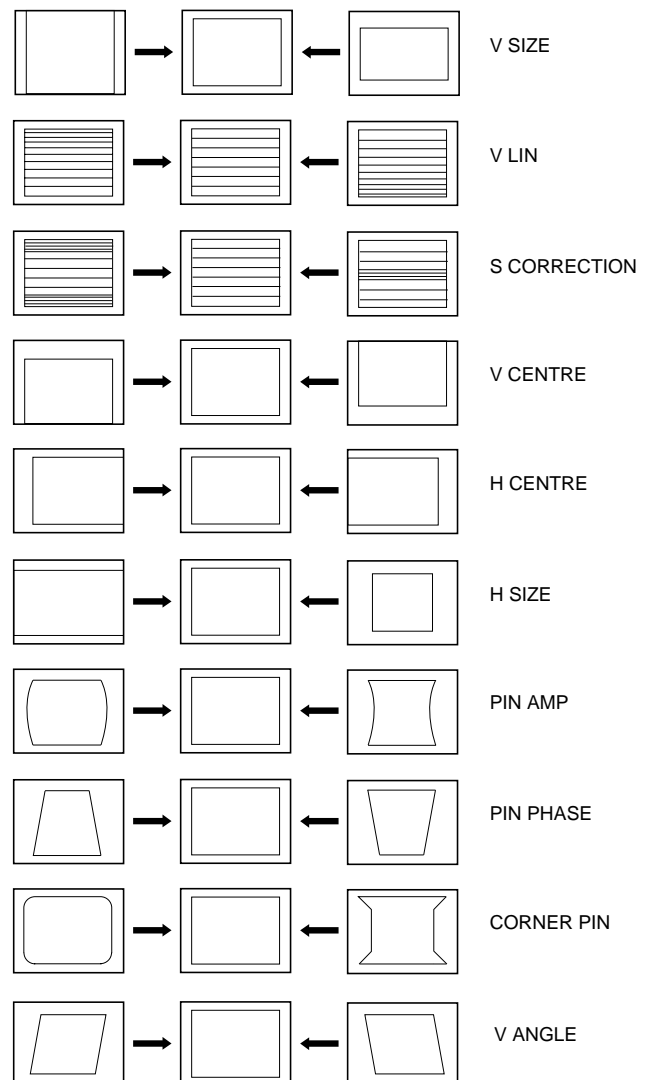

4-2. TEST MODE 1:

Test Mode 1 is available by pressing the 'TEST' button once, OSD 'T' appears. The functions described below are available by selecting the indicated keys. The 'T' is released automatically after each command is executed.

KEY	T-MODE FUNCTION
volume +	volume maximum
volume -	Picture minimum
picture +	Picture maximum
picture -	Picture minimum
colour up	colour maximum
colour down	colour minimum
brightness - bright	brightness maximum
brightness - dark	brightness minimum
hue - purplish	hue - purplish
hue - greenish	hue - greenish
sharpness - sharp	sharpness maximum
sharpness - soft	sharpness minimum
balance left	balance full left
balance right	balance full right
treble up	treble maximum
treble down	treble minimum
bass up	bass maximum
bass down	bass minimum

4-3. TEST MODE 2:

Test Mode 2 is available by pressing the 'TEST' button twice, OSD 'TT' appears. The functions described below are available by selecting the two numbers. To release the 'Test mode 2', press 00, 10, 20 ... twice or switch the TV set into Stand-by mode. In 'TT Menu' mode, it is possible to remove the Menu from the screen by pressing the Speaker Off button once. Pressing the Speaker OFF button a second time will cause the Menu to reappear. The function is kept even when the menu is not displayed on screen !!.

00	'TT' mode off
01	Picture maximum
02	Picture minimum
03	Set speaker/headphone Volume to 35%
04	Set speaker/headphone Volume to 50%
05	Set speaker/headphone Volume to 65%
06	Set speaker/headphone Volume to 80%
07	Ageing mode
08	Shipping Condition
11	Sub picture adjustment
12	Sub colour adjustment
13	Sub Brightness adjustment
14	Text H Position adjustment
15	Rotation Coil Test
16	Picture level 50%
19	Factory Mode Enable/Disable
21	Destination ADEKR
22	Destination BL
23	Destination ADEKR
24	Destination U
25	Destination ADEKR
26	Destination BL

27	Destination ADEKR
28	Destination ADEKR
31	Auto Shutoff Enable/Disable
33	Rotation ON/OFF
35	CRT 4:3 <> 16:9 ; Display TV status
36	Velocity Modulation (VM) OFF/ON test
38	G2 adjustment
41	Re-initialise NVM
43	Select Dual A sound
44	Select Dual B sound
45	Select Mono sound
46	Select Stereo sound
48	Set NVM as non virgin
49	Set NVM as virgin
51	Virtual Dolby on/off
52	Subwoofer / MPB (Bass enhancement) Enable
54	Dot structure C/M (chroma trap)ination ADEKR
55	Tuner selection (SONY//ALPS)
56	BBE enable/disable
57	BBE menu line enable/disable
61	Auto AGC Adjustment
62	AM from baseband enable/disable
63	Enable/Disable YC3 connector
64	Enable/Disable RGB priority
65	RGB auto-detect enable/disable
66	On timer enable/disable
67	Manual AGC Adjustment
68	Enable/Disable X26 countermeasure (N problem)
69	Enable/Disable ACI feature
71	Force PAL video
72	Un-force PAL (restore normal video condition)
73	Enable Zweiton D/K2 system (6.5/6.74)
74	Enable Zweiton D/K3 system (6.5/5.74)
78	Balance full left
79	Balance full right
87	Local keys test
89	Enable/Disable watchdog
91	Set 14:9 zoom mode
92	Set SMART zoom mode
93	Set 16:9 zoom mode
94	Set ZOOM mode
95	Set 4:3 zoom mode
99	Display Error and Working Time menu

5-1. BLOCK DIAGRAMS (1)

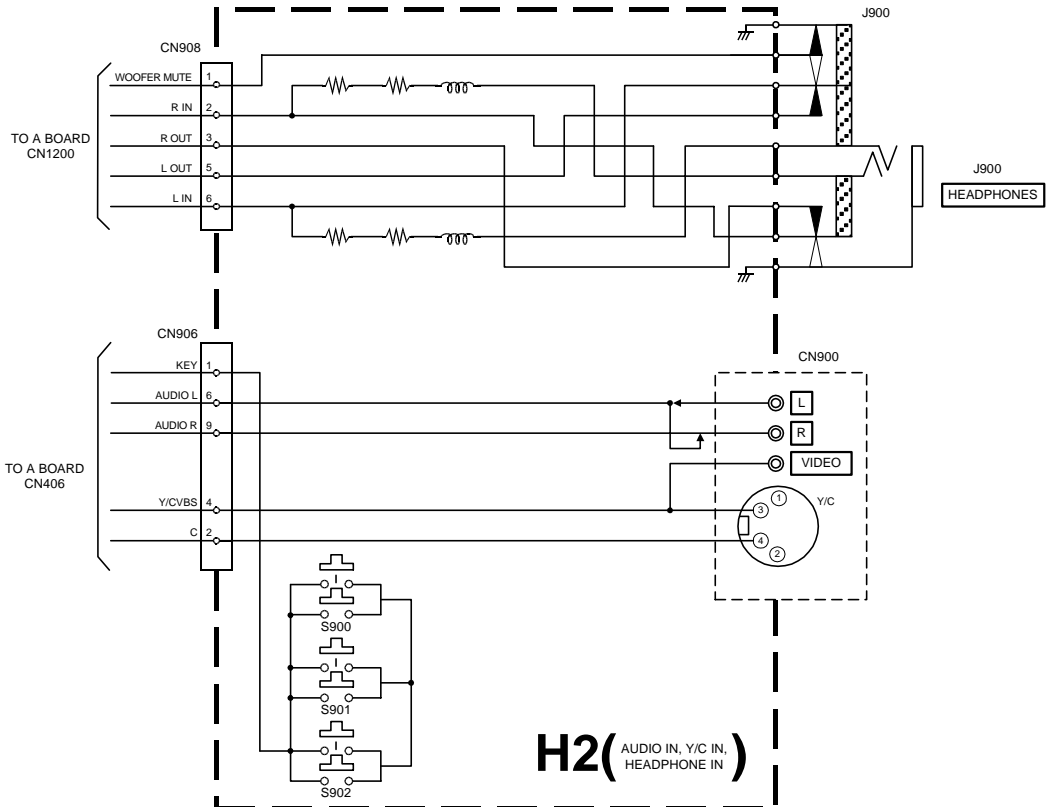
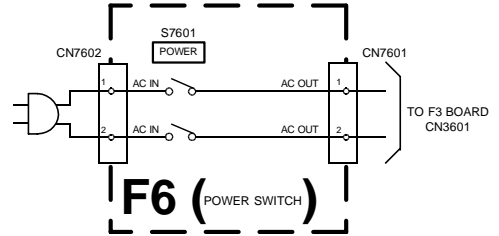
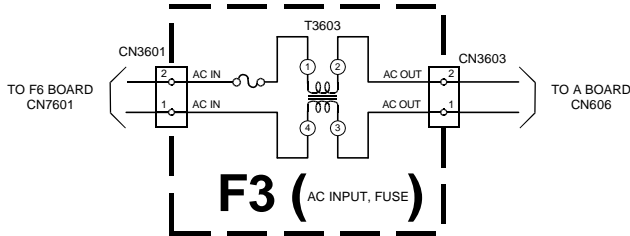
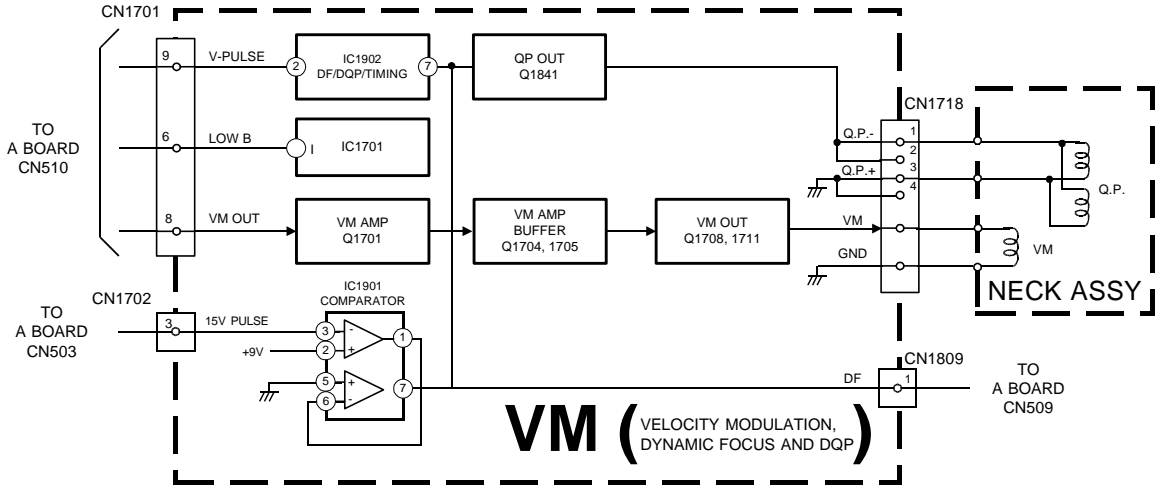

5-1. BLOCK DIAGRAMS (2)

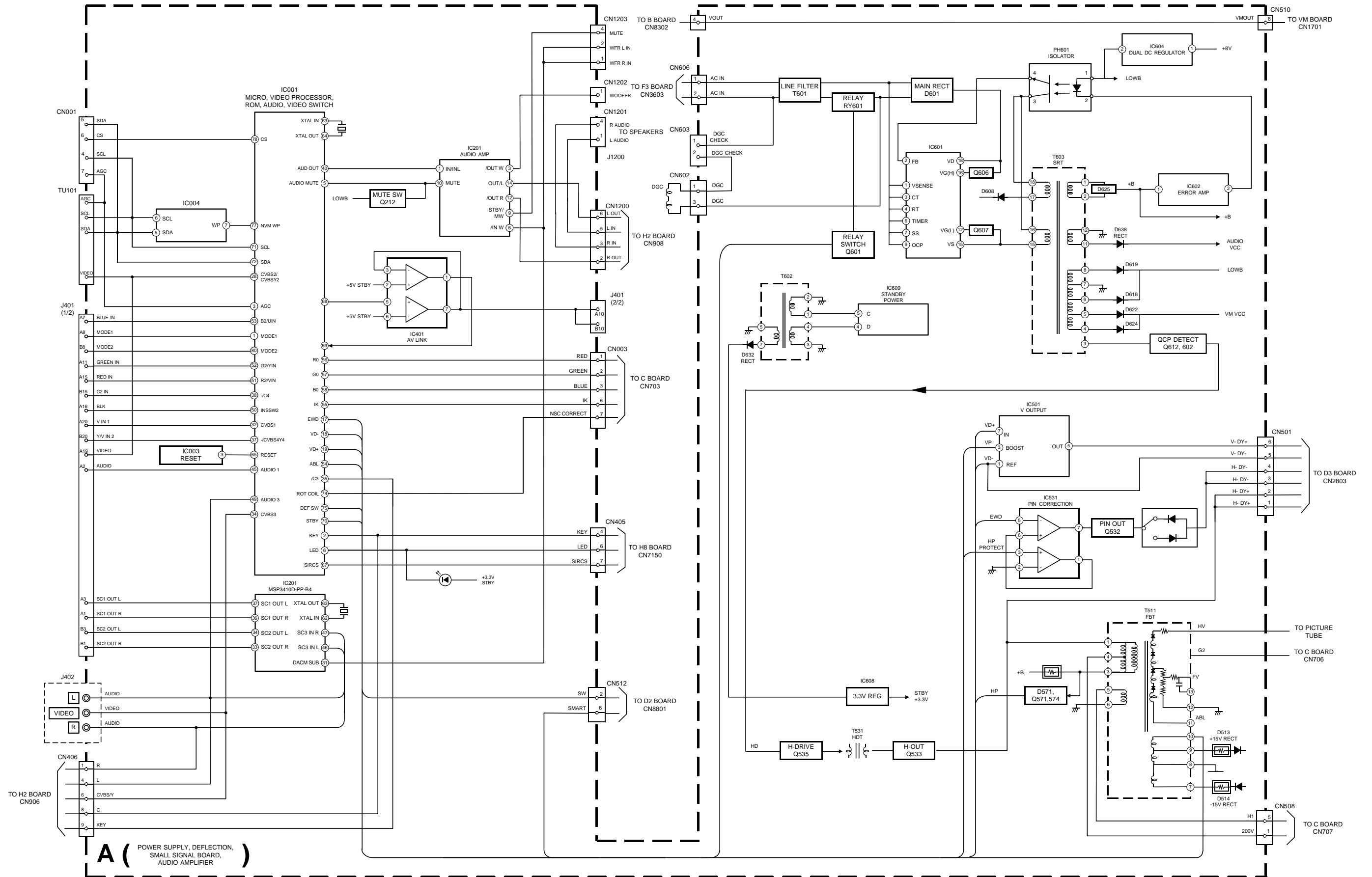

5-1. BLOCK DIAGRAMS (3)

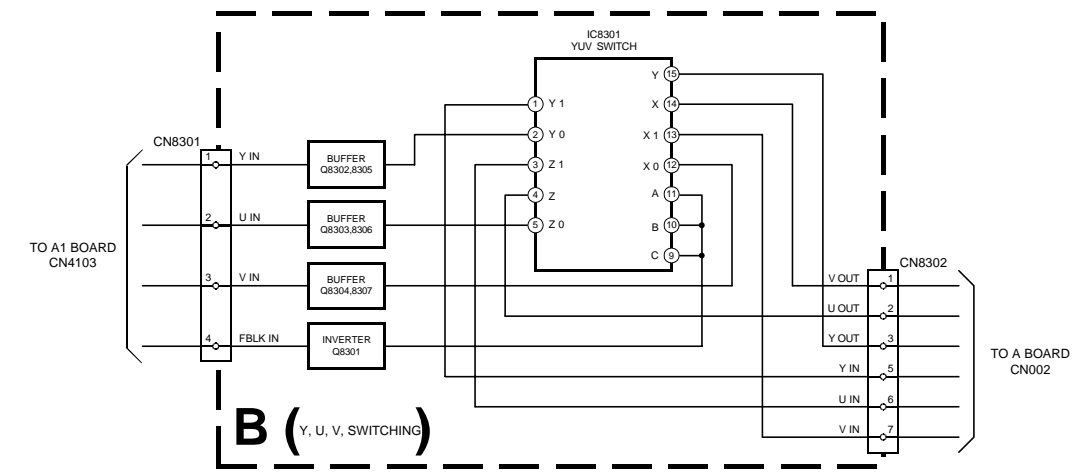
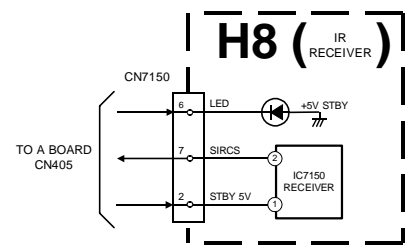
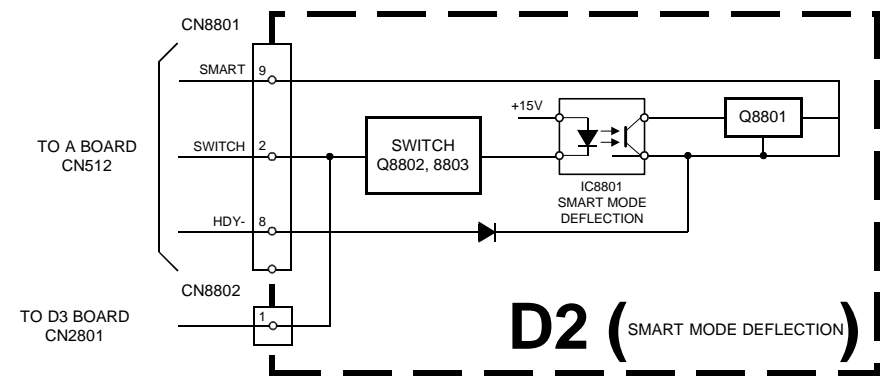
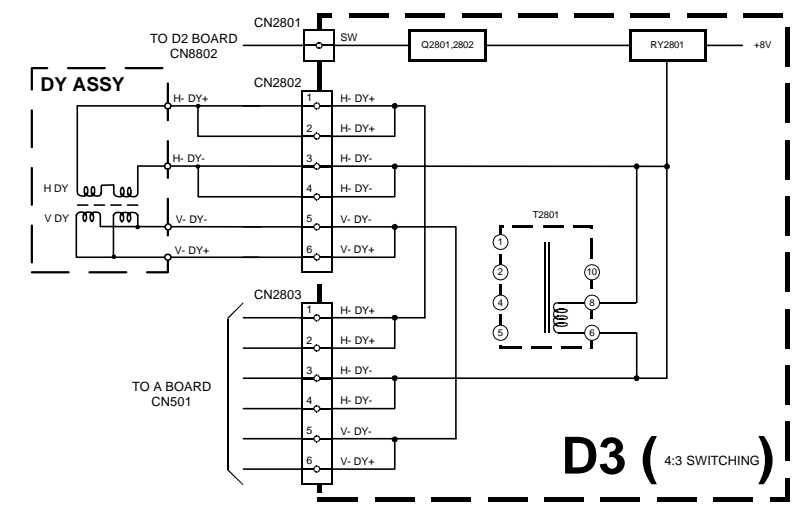
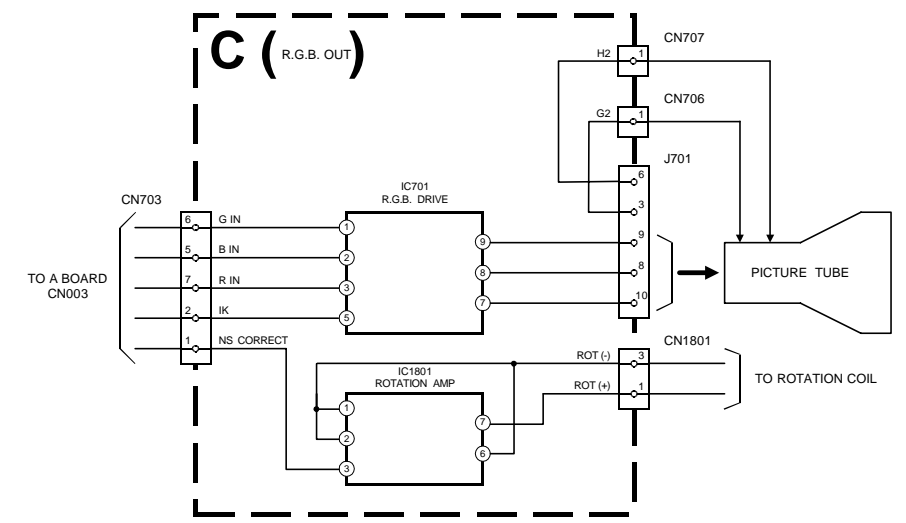
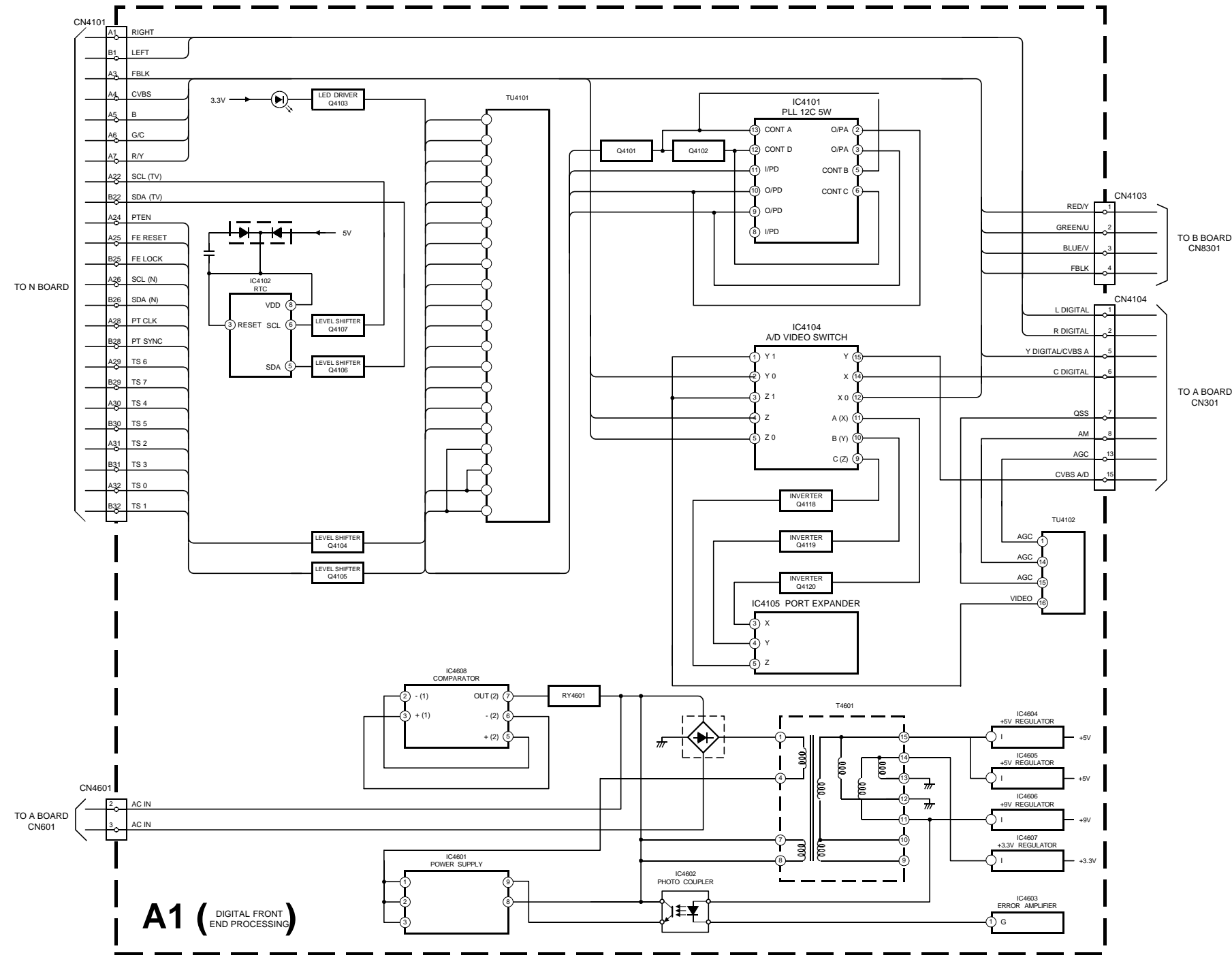

5-2. CIRCUIT BOARD LOCATION

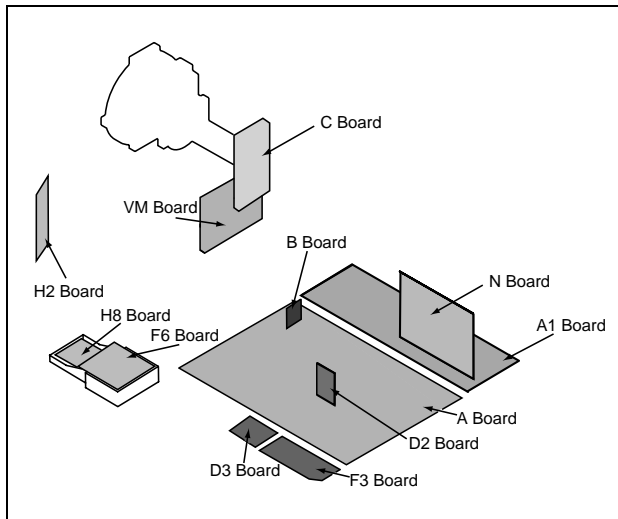









5-3. SCHEMATIC DIAGRAMS AND PRINTED WIRING BOARDS

Note :

- All capacitors are in μF unless otherwise noted.
- pF : μF 50WV or less are not indicated except for electrolytic types.
- Indication of resistance, which does not have one for rating electrical power, is as follows.

Pitch : 5mm
Electrical power rating : 1/4W

- Chip resistors are 1/10W
- All resistors are in ohms.
k = 1000 ohms, M = 1000,000 ohms
-  : nonflammable resistor.
-  : fusible resistor.
-  : internal component.
-  : panel designation or adjustment for repair.
- All variable and adjustable resistors have characteristic curve B, unless otherwise noted.
- All voltages are in Volts.
- Readings are taken with a 10Mohm digital mutimeter.
- Readings are taken with a color bar input signal.
- Voltage variations may be noted due to normal production tolerences.
-  : B + bus.
-  : B - bus.
-  : RF signal path.
-  : earth - ground.
-  : earth - chassis.

Reference Information

RESISTOR	RN	: METAL FILM
	RC	: SOLID
	FPRD	: NON FLAMMABLE CARBON
	FUSE	: NON FLAMMABLE FUSIBLE
	RS	: NON FLAMMABLE METAL OXIDE
	RB	: NON FLAMMABLE CEMENT
	RW	: NON FLAMMABLE WIREWOUND
		: ADJUSTMENT RESISTOR
COIL	LF-8L	: MICRO INDUCTOR
CAPACITOR	TA	: TANTALUM
	PS	: STYROL
	PP	: POLYPROPYLENE
	PT	: MYLAR
	MPS	: METALIZED POLYESTER
	MPP	: METALIZED POLYPROPYLENE
	ALB	: BIPOLAR
	ALT	: HIGH TEMPERATURE
	ALR	: HIGH RIPPLE

Note : The components identified by shading and marked  are critical for safety. Replace only with the part numbers specified in the parts list.

Note : Les composants identifiés par une trame et par une marque  sont d'une importance critique pour la sécurité. Ne les remplacer que par des pièces de numéro spécifié.

~ A Board IC Voltage Table~

Ref No	Pin No	Voltage (V)	Ref No	Pin No	Voltage (V)
IC001	1	0	IC001	67	4.8
	2	3.2		68	0.4
	3	2.9		69	0
	5	0		70	0
	6	2.0		71	0
	8	2.3		72	0
	9	8.0		73	7.1
	10	5.0		74	5.0
	12	0		75	8.1
	13	0		76	-3.5
	14	4.0		77	0
	16	1.4		78	3.2
	17	1.5		79	3.2
	18	0		80	0
	19	0		1	0.3
	20	3.8		3	-12.6
	21	3.8	5	0.2	
	22	5.0	6	13.9	
	26	0	7	0.3	
	28	3.5	1	1.4	
	29	3.6	2	2.3	
	30	1.9	3	1.8	
	31	0.3	5	2.4	
	32	3.6	6	1.6	
	34	1.9	7	6.4	
	35	1.4	1	-80.4	
	36	3.9	2	-80.5	
	38	1.8	3	-80.2	
	40	3.3	4	-80.2	
	42	3.3	5	-81.5	
	43	1.4	6	-81.6	
	45	0	7	-77.8	
	46	0	9	-81.8	
	47	3.6	10	-76	
	48	2.8	11	-81.9	
	49	2.3	12	-79.4	
	50	0.2	14	16.5	
	51	2.5	15	11	
	52	2.5	16	14.4	
	53	2.5	18	86.4	
	54	2.1	1	11	
	55	5.2	3	4.9	
	56	3.0	5	0	
	57	3.1	6	0	
	58	3.1	7	11.3	
	59	3.2	9	0.3	
	62	0	10	0	
	63	0	12	0	
	64	0	14	11.35	
	65	0			

~ A Board Difference Table~

Ref	28DX40U	32DX40U
C522	0.27UF	-
C536	0.82UF	1UF
C539	1UF	2.2UF
C542	330PF	0.001UF
C547	0.82UF	0.68UF
C555	22000PF	19000PF
JR101	-	0
R022	47K	39K
R053	15K	82K
R455	0	4.7UH
R513	220K	-
R516	56K	47K
R517	18K	22K
R518	2.7K	6.8K
R521	220K	-
R534	100K	390K
R535	120K	220K
R540	33	47
R546	820	1K
R568	680	820
R583	10K	15K
R600	390	120
R601	470	680
T533	1-433-980-12 TRANSFORMER	1-429-306-11 TRANSFORMER

~ A Board Semiconductor Voltage Table ~

Ref	(e)	(b)	(c)	Ref	(e)	(b)	(c)
Q013	0	0.7	0	Q604	0	0	2.5
Q016	0	0	3.3	Q608	0	0	5.6
Q212	0	0.7	0	Q609	5.6	5.6	0
Q401	4.8	4.2	1.8				
Q411	1.1	1.7	4.2	Ref	(s)	(g)	(d)
Q601	5.6	4.8	5.3	Q606	10.9	14.5	86.7
Q602	14.2	5.1	8	Q607	-82.4	-79.9	10.9
Q603	8	8	0	Q535	0	2.5	95.2

~ A Board Waveforms ~

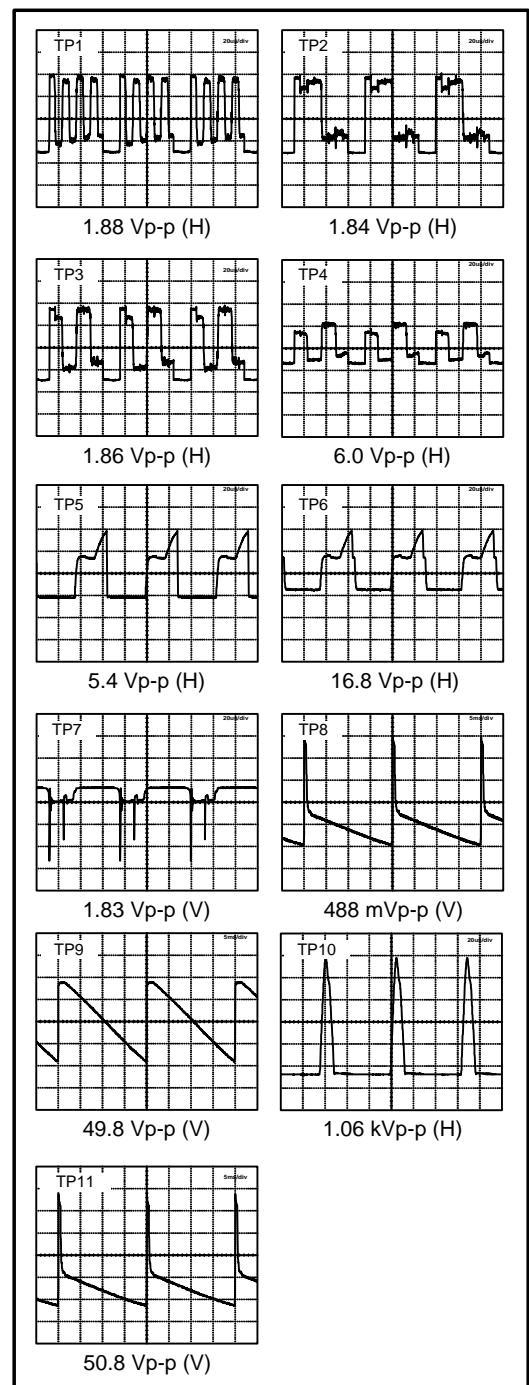

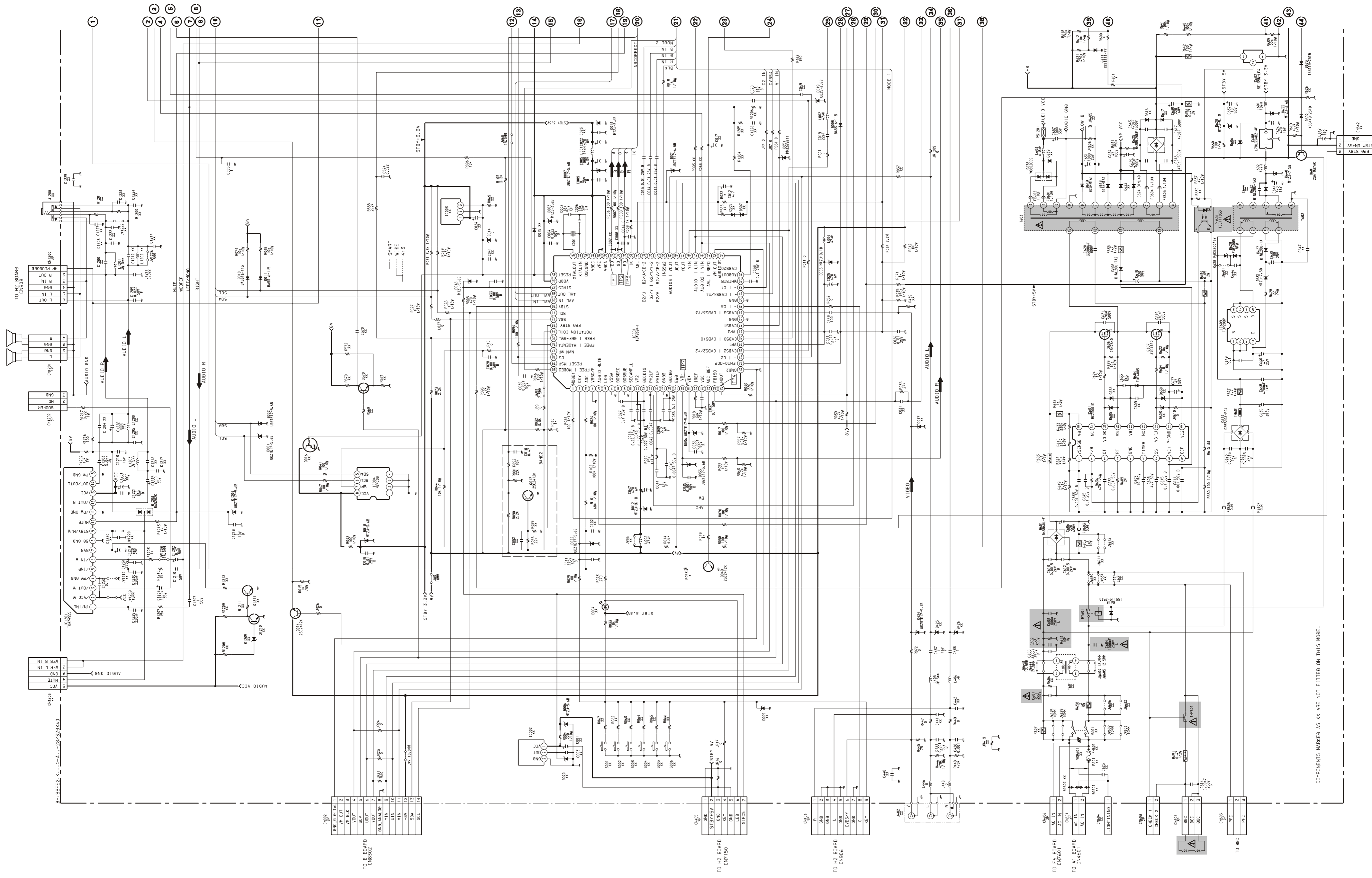

COMPONENTS MARKED AS XX ARE NOT FITTED ON THIS MODEL

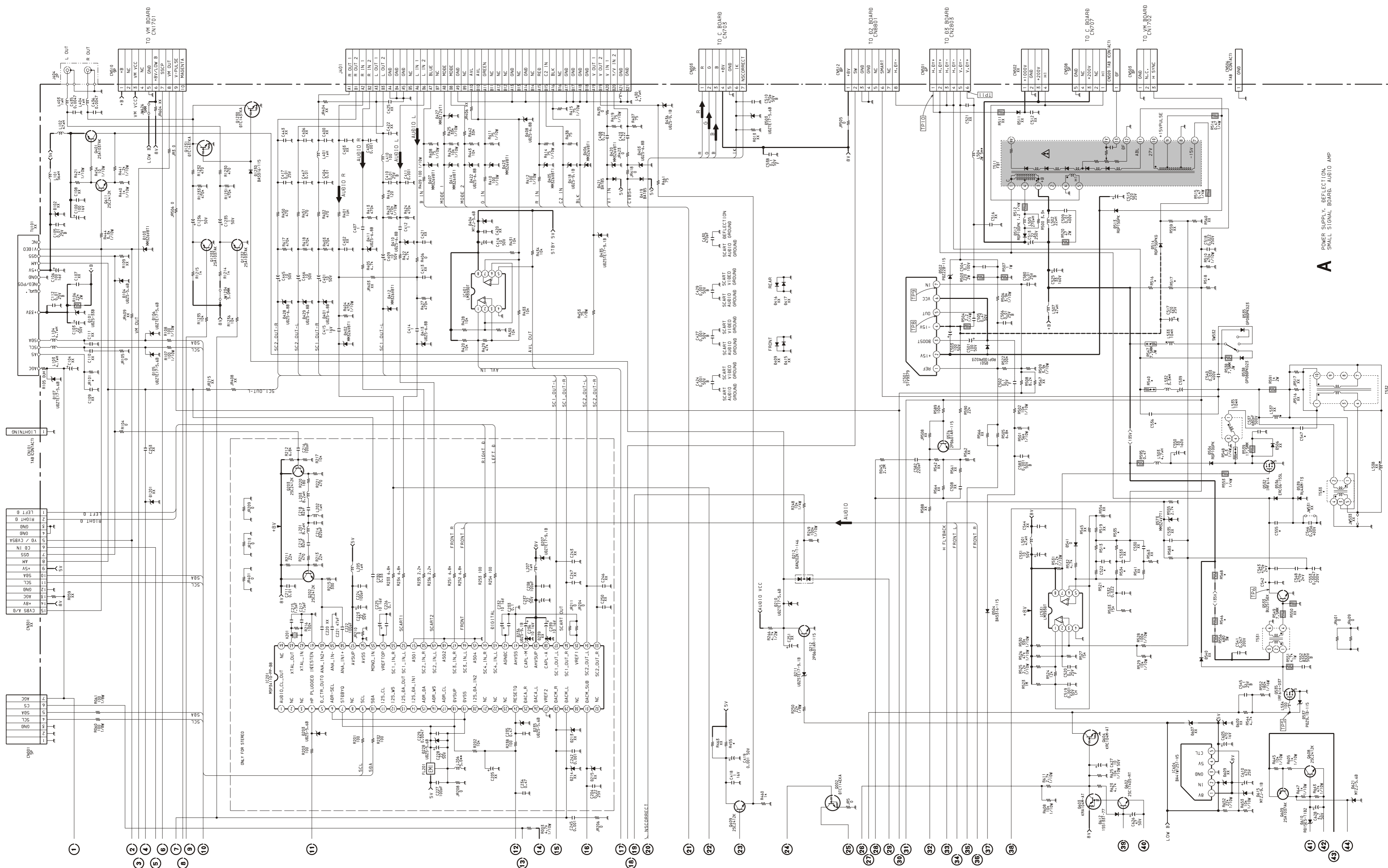

A POWER SUPPLY, DEFLECTION, SMALL SIGNAL BOARD, AUDIO AMP

A B C D E F G H I J K L M N

1
2
3
4
5
6
7
8
9
10
11

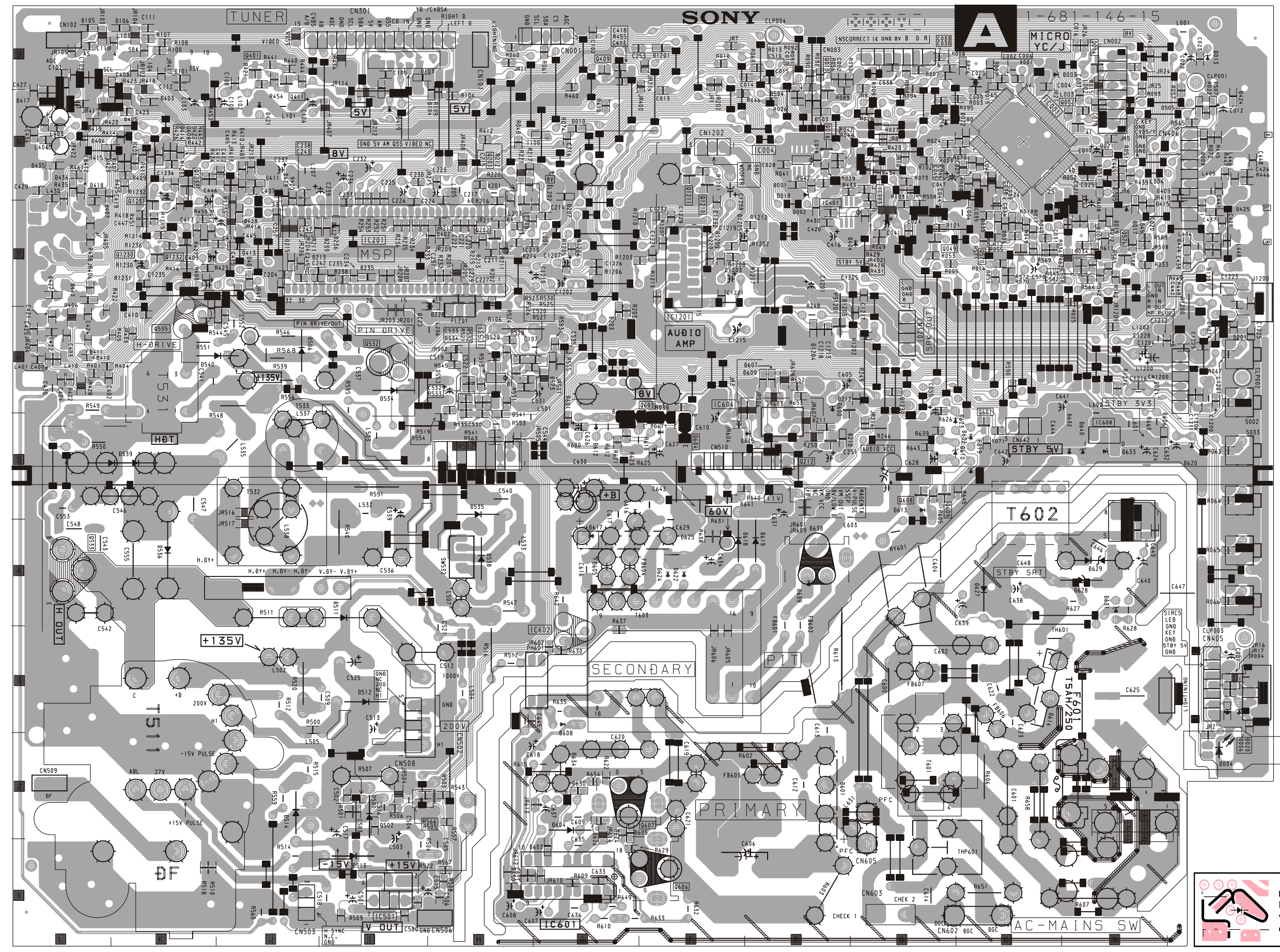

~ A Board Semiconductor Location Table ~

DIODE		TRANSISTOR	
D001	I-2	D421	C-2
D002	I-3	D422	C-2
D003	K-2	D423	C-2
D004	M-4	D424	M-2
D006	M-8	D427	A-4
D007	K-1	D428	C-3
D008	L-3	D429	D-3
D010	G-2	D435	A-2
D011	F-2	D436	A-2
D013	M-1	D501	D-9
D016	J-2	D502	D-9
D018	I-3	D503	I-2
D020	M-8	D504	I-2
D021	L-2	D505	M-2
D022	J-2	D506	D-4
D035	K-3	D507	M-2
D036	K-3	D512	D-8
D051	L-3	D513	D-9
D101	B-1	D514	C-9
D103	E-1	D534	E-5
D104	E-2	D535	E-6
D105	A-1	D536	B-6
D106	B-1	D537	C-4
D107	B-2	D538	E-6
D207	F-3	D539	B-5
D210	I-5	D541	F-5
D211	I-5	D573	F-5
D212	I-5	D601	I-9
D228	E-4	D602	J-5
D236	D-3	D604	F-9
D239	D-3	D608	F-8
D402	E-3	D610	J-5
D403	B-2	D611	G-5
D404	I-3	D612	G-5
D405	B-2	D613	J-6
D406	B-2	D614	K-8
D407	B-2	D615	H-5
D408	B-2	D618	H-6
D410	C-2	D619	H-6
D411	C-3	D620	M-5
D412	D-3	D621	J-5
D413	C-3	D622	H-7
D414	B-2	D623	J-5
D418	B-3	D625	H-6
D419	E-2	D626	K-7
D420	B-2	D628	L-7
		D629	L-7

IC'S	
IC001	K-2
IC002	M-8
IC004	H-2
IC401	I-3
IC501	E-10
IC531	F-4
IC601	F-10
IC602	F-7
IC604	H-5
IC608	L-5
IC609	L-6
IC2101	H-4

 NOTE:
Portions of the circuit marked as shown are high voltage areas. Use care to prevent electric shock during inspection or repair.

~ A Printed Wiring Board Conductor side ~

~ C Board Schematic [R-G-B Out] ~

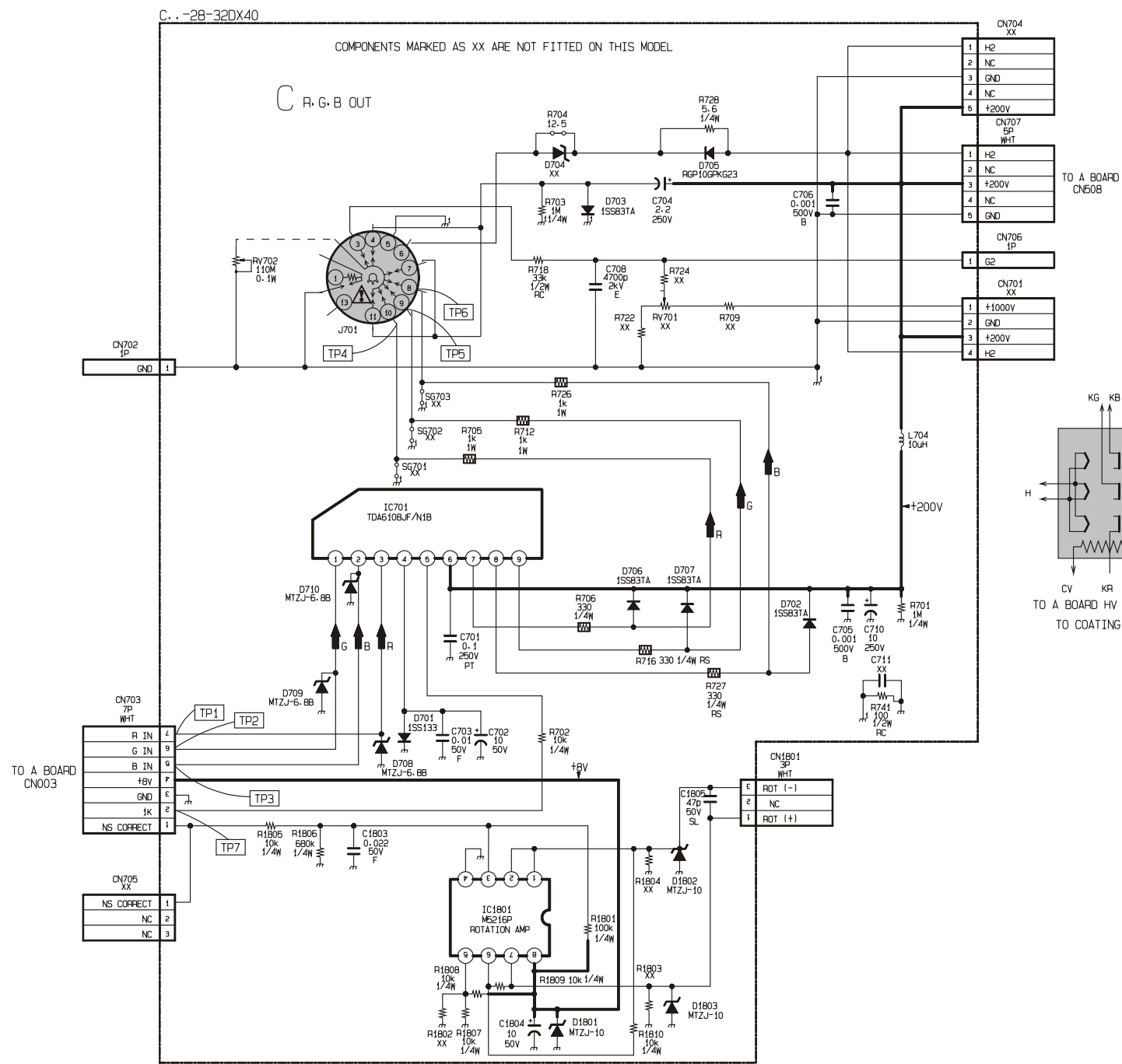

~ VM Printed Wiring Board ~

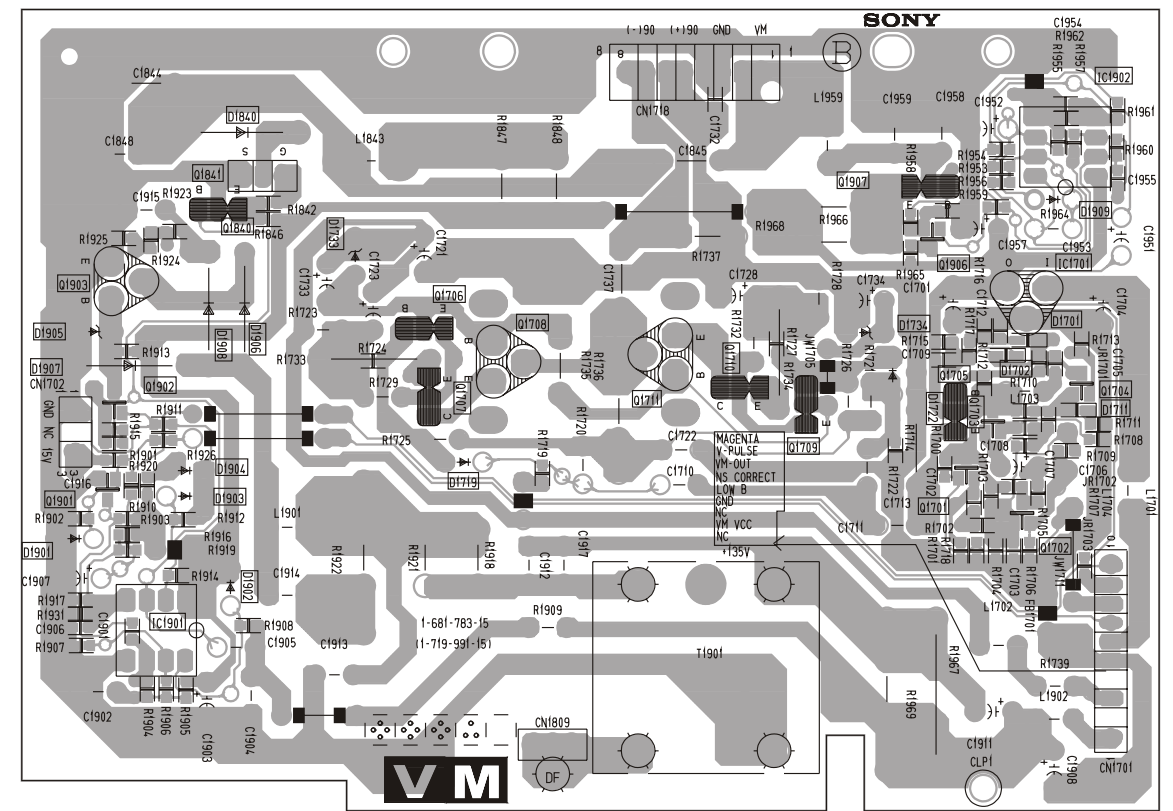

~ C Board Waveforms ~

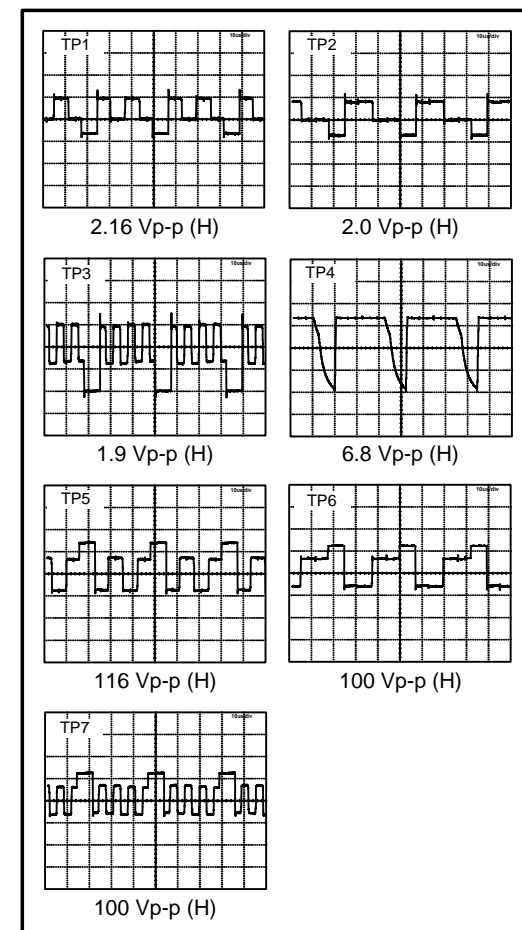

~ C Printed Wiring Board ~

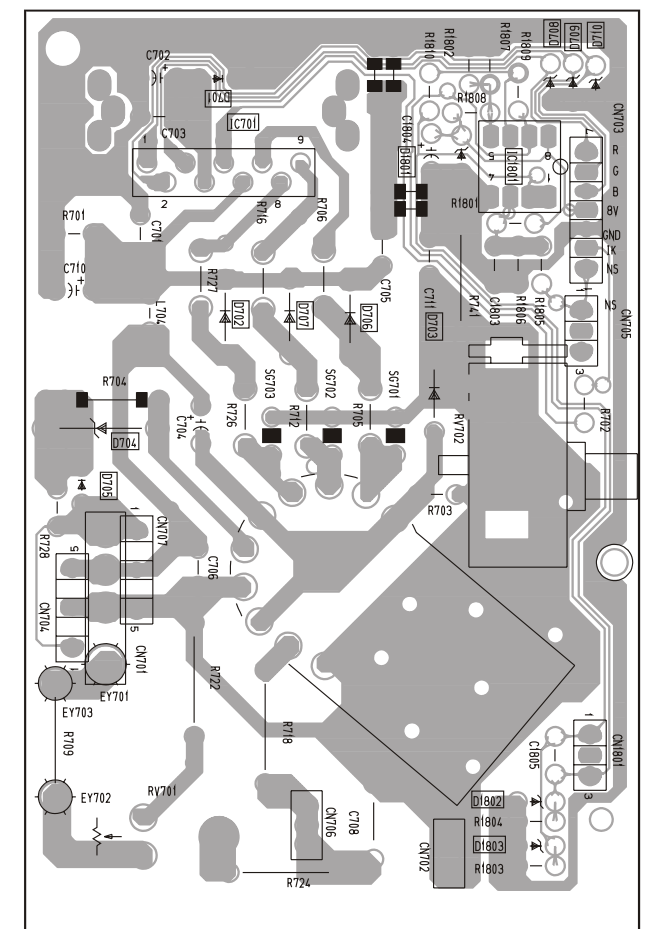

~ C Board Semiconductor Voltages ~

Ref	(e)	(b)	(c)	Ref	(e)	(b)	(c)	Ref	(e)	(b)	(c)
Q701	124.2	124.8	202	Q706	7.5	8.1	125.0	Q712	125.8	126.4	201.9
Q702	2.3	3.0	7.5	Q707	124.6	125.8	5.5	Q713	133.0	132.4	201.9
Q703	7.5	8.1	131.6	Q708	3.5	2.1	7.5	Q715	132.3	131.5	8.1
Q704	131	132.4	5.2	Q709	7.5	8.1	123.3	Q716	125.8	125.0	8.1
Q705	2.5	3.1	7.5	Q710	123.0	124.3	5.5	Q717	124.2	123.4	8.1

~ C Board IC Voltages ~

Ref No	Pin No	Voltage (V)	Ref No	Pin No	Voltage (V)
IC1701	1	3.1	IC1801	1	1.3
	2	2.1		2	1.3
	3	3.0		3	1.4
	5	5.5		5	4.1
	7	131		6	4.1
8	123	7	7.0		
9	124.6	8	8.0		

VM VELOCITY MODULATION DYNAMIC FOCUS AND DQP

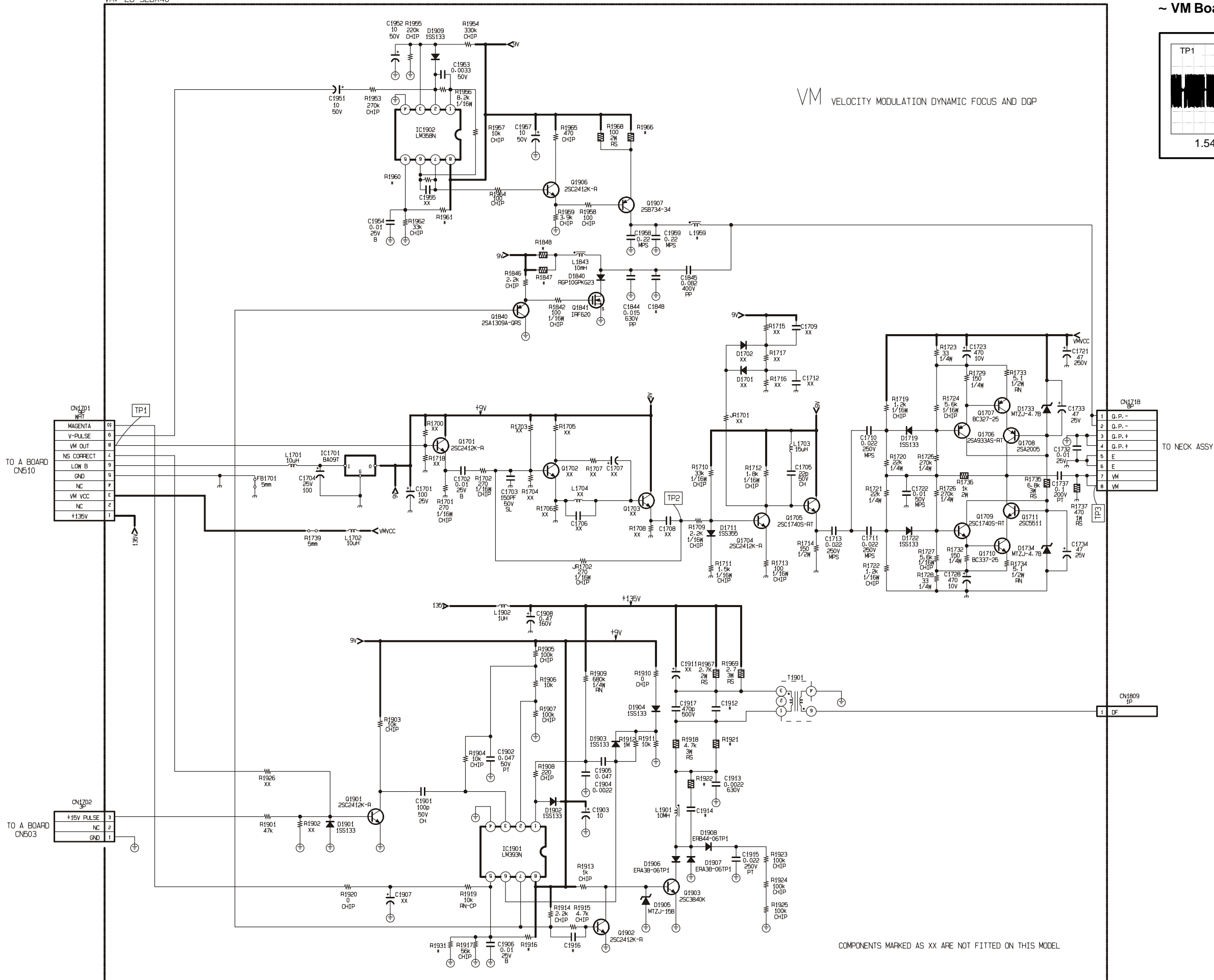

~ VM Board Waveforms ~

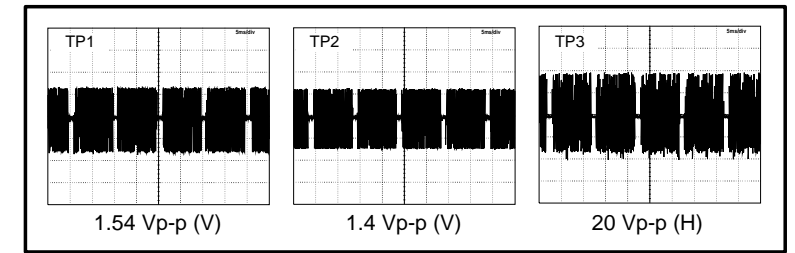

~ VM Board Semiconductor Voltages ~

Ref	(e)	(b)	(c)
Q1701	6.9	7.5	9.0
Q1704	6.0	6.6	8.7
Q1705	5.9	6.0	9.0
Q1706	45.4	44.5	68
Q1707	44.6	45.4	135.1
Q1708	135.1	134.6	68
Q1709	1.2	1.8	1.4
Q1710	0.5	1.2	0.8
Q1711	0.8	1.4	68

~ VM Schematic [Velocity Modulation] ~
[Dynamic Focus and DQP]

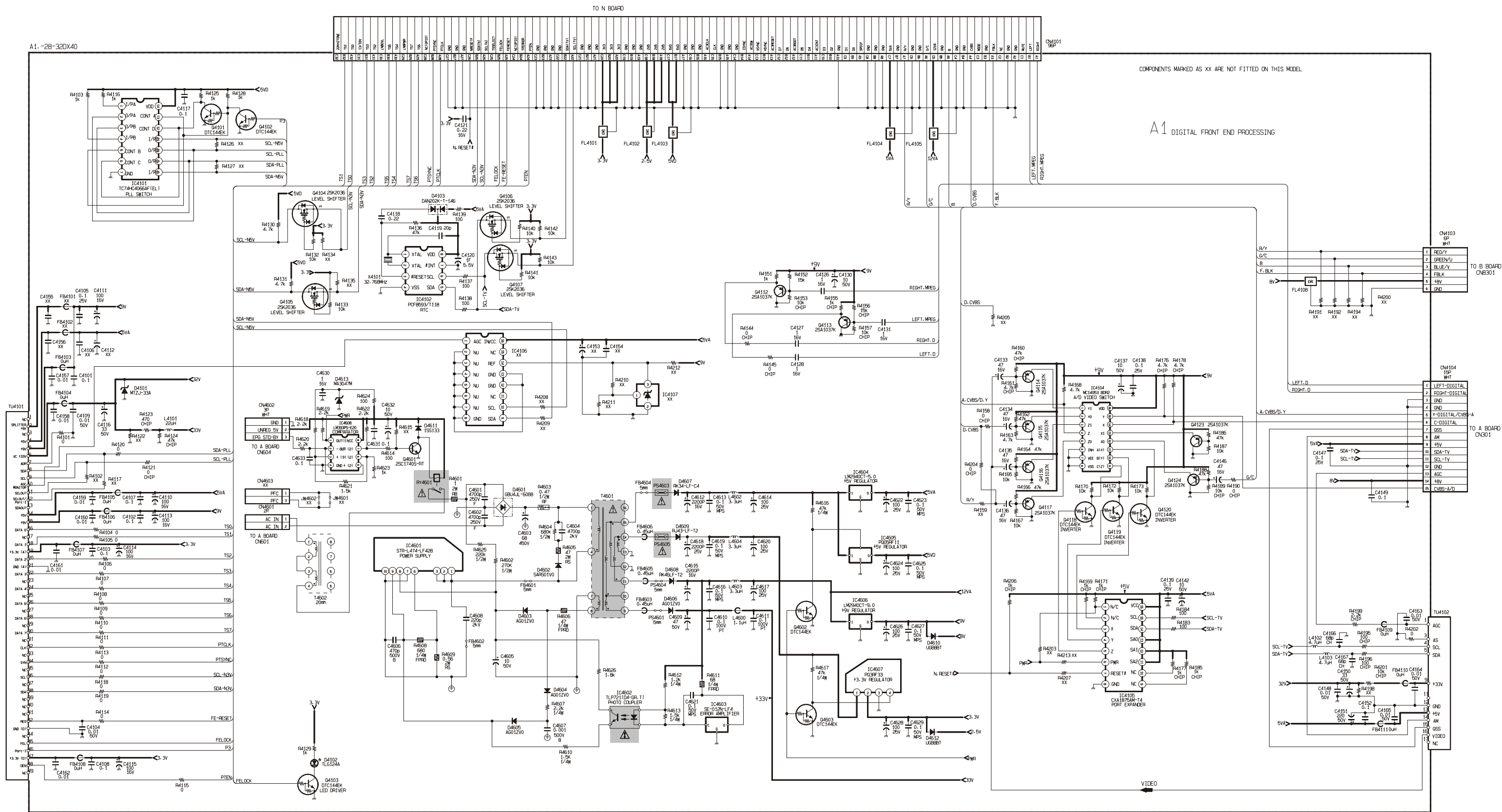

~ A1 Schematic [Digital Front End Processing] ~

A B C D E F G H I J K L M N

~ A1 Printed Wiring Board Conductor side A ~

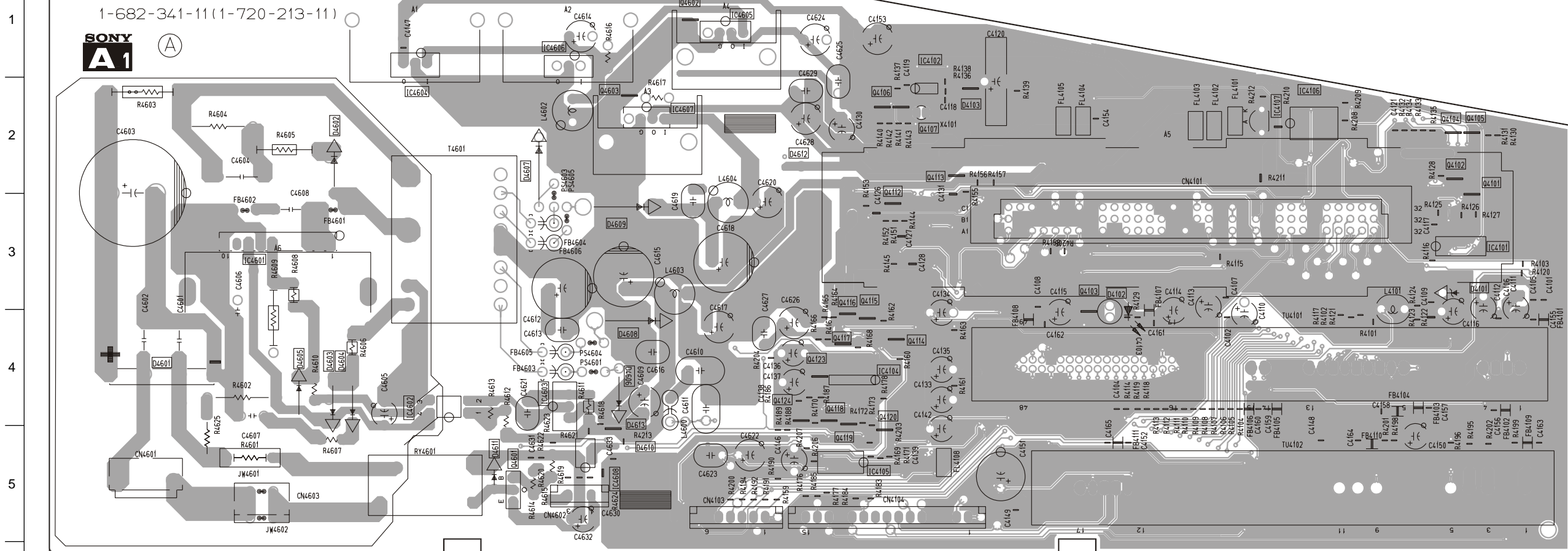

~ A1 Board Semiconductor Location Table (side A) ~

DIODE		
D4101	M - 3	IC4605 G - 1
D4102	J - 4	IC4606 E - 1
D4103	I - 2	IC4607 F - 2
D4601	B - 4	IC4608 F - 5
TRANSISTOR		
D4602	C - 2	Q4101 M - 2
D4603	C - 4	Q4102 M - 2
D4604	C - 4	Q4103 J - 3
D4605	C - 4	Q4104 M - 2
D4606	F - 4	Q4105 M - 2
D4607	E - 2	Q4106 H - 2
D4608	F - 4	Q4107 H - 2
D4609	F - 3	Q4112 H - 2
D4610	F - 5	Q4113 H - 2
D4611	D - 5	Q4114 H - 4
D4612	G - 2	Q4115 H - 3
D4613	F - 4	Q4116 H - 3
		Q4117 G - 4
IC		
IC4101	M - 3	Q4118 G - 4
IC4102	H - 2	Q4119 H - 4
IC4104	H - 4	D4120 H - 5
IC4105	H - 5	D4123 G - 4
IC4106	L - 5	D4124 G - 4
IC4601	B - 3	D4601 F - 5
IC4602	D - 4	D4602 F - 1
IC4603	E - 4	D4603 F - 2
IC4604	D - 1	

~ A1 Printed Wiring Board Conductor side B ~

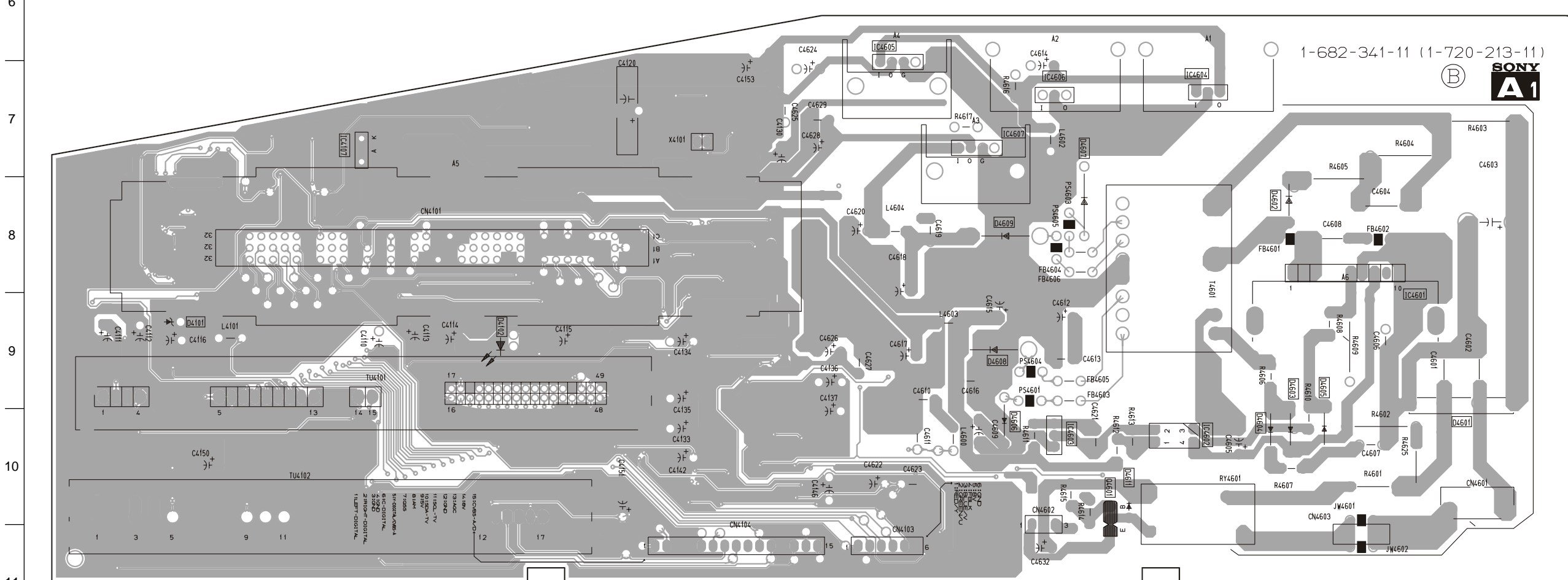

~ A1 Board Semiconductor Location Table (side B) ~

DIODE			
D4101	B - 9	IC	
D4102	D - 9	IC4107	C - 7
D4601	M - 10	IC4601	L - 8
D4602	K - 8	IC4602	J - 10
D4603	K - 10	IC4603	I - 10
D4604	K - 10	IC4604	K - 7
D4605	K - 10	IC4605	H - 7
D4606	I - 10	IC4606	I - 7
D4607	J - 8	TRANSISTOR	
D4608	I - 9	Q4601	J - 10
D4609	I - 8		

~ B Schematic [Y.U.V. Switching] ~

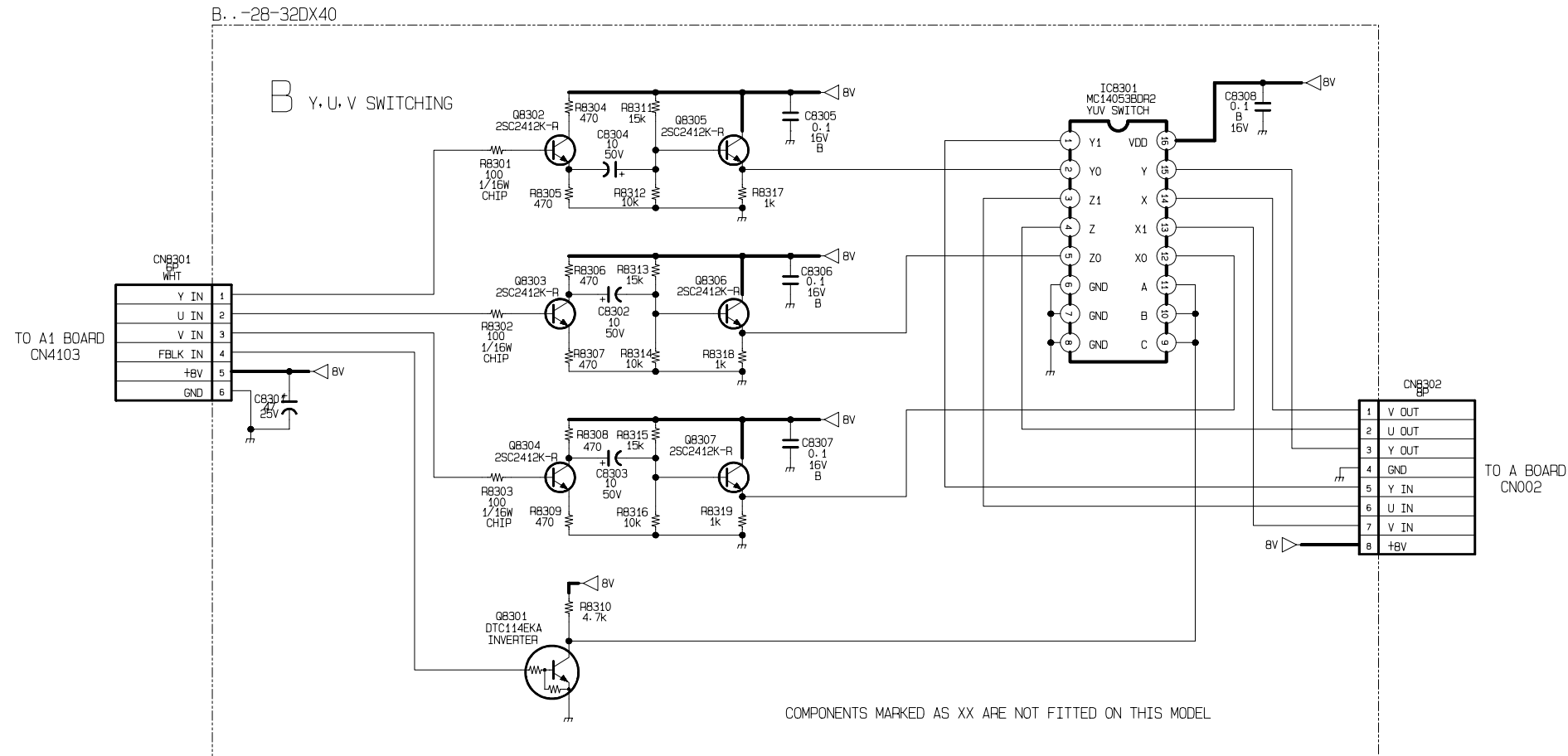

~ B Printed Wiring Board ~

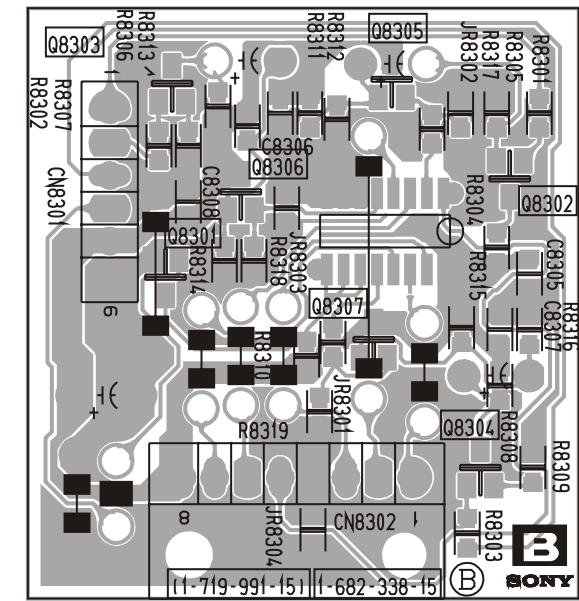

~ H2 Schematic [Y/C In, Audio In, Headphone In] ~

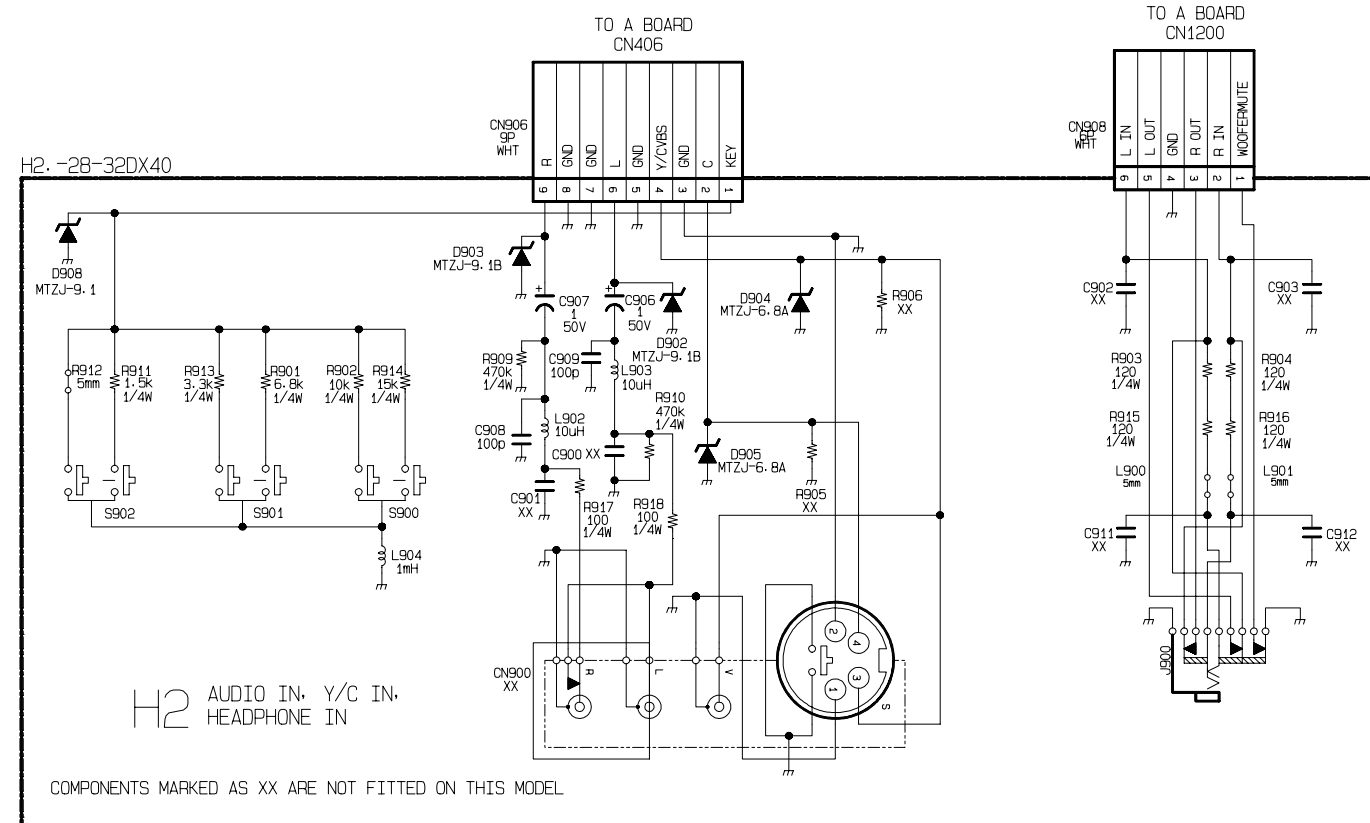

~ H2 Printed Wiring Board ~

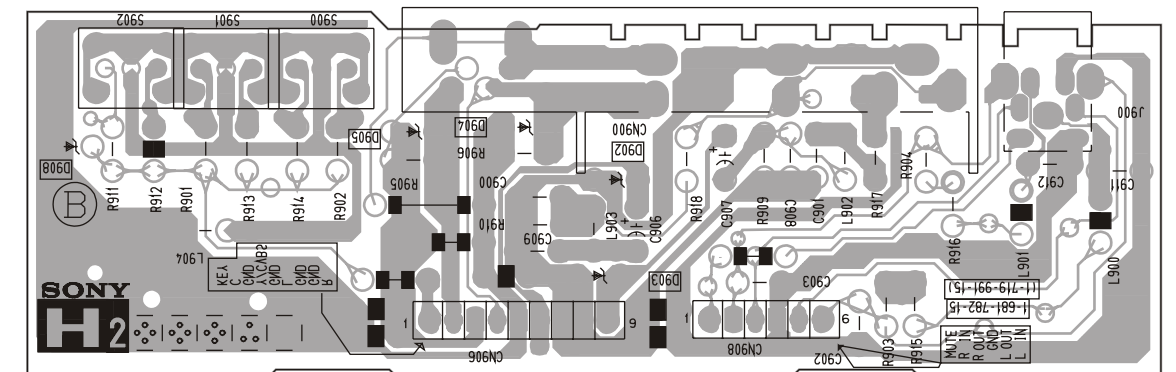

~ D3 Schematic [4:3 Switching] ~

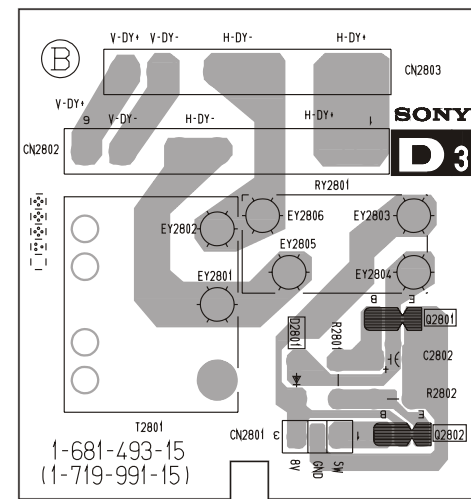
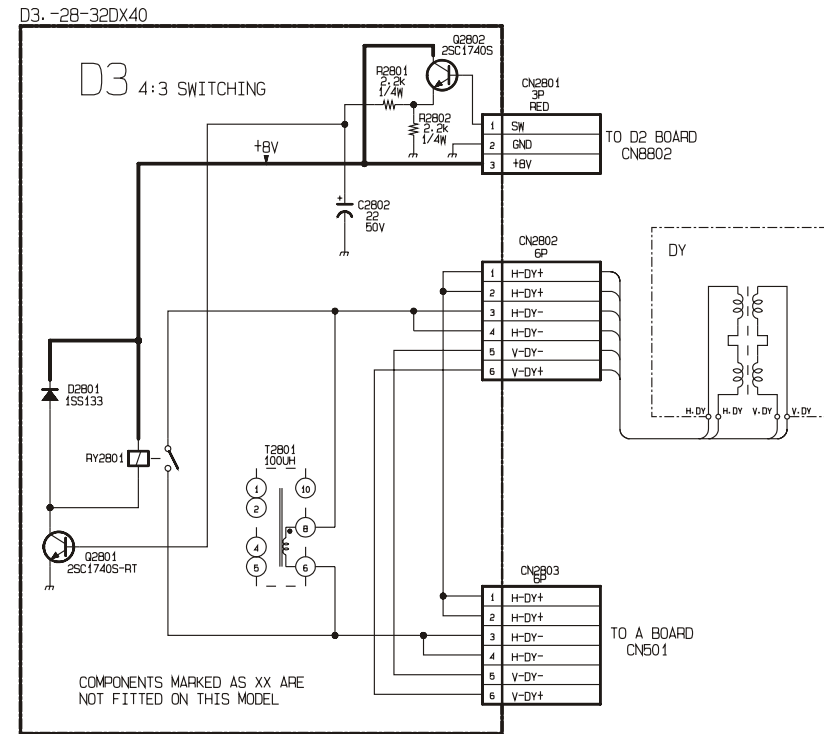

~ D3 Printed Wiring Board ~

~ H8 Schematic [LED and SIRCS Response] ~

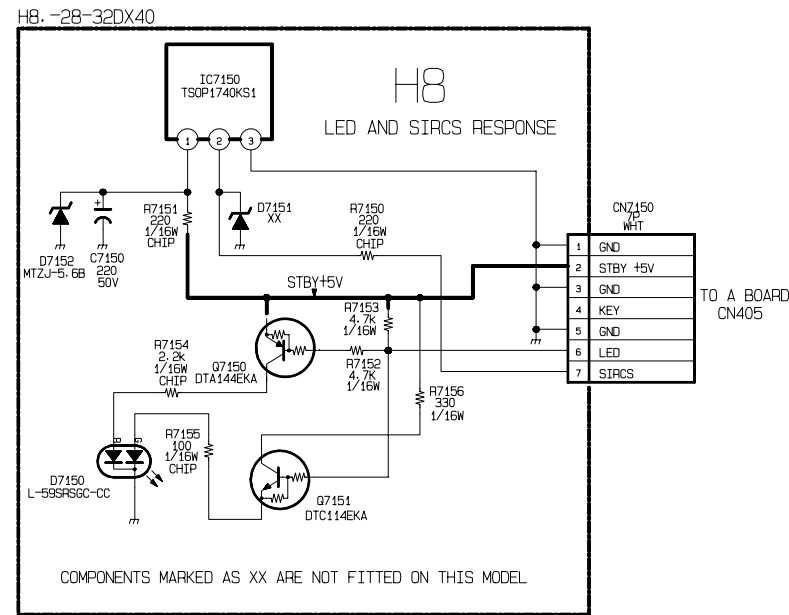

~ H8 Printed Wiring Board ~

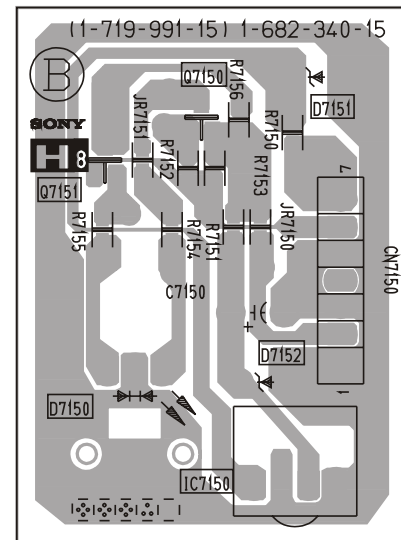

~ D2 Printed Wiring Board ~

~ D2 Schematic [Smart Mode Deflection] ~

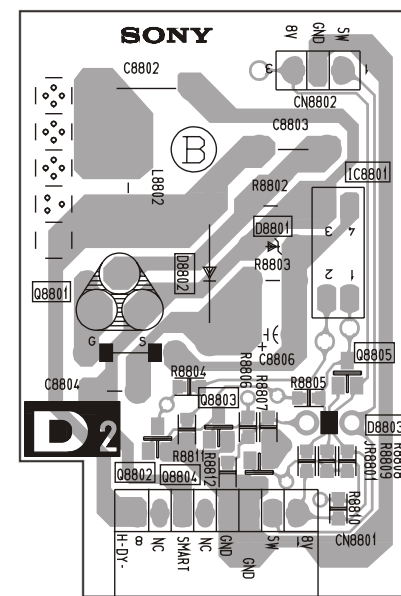
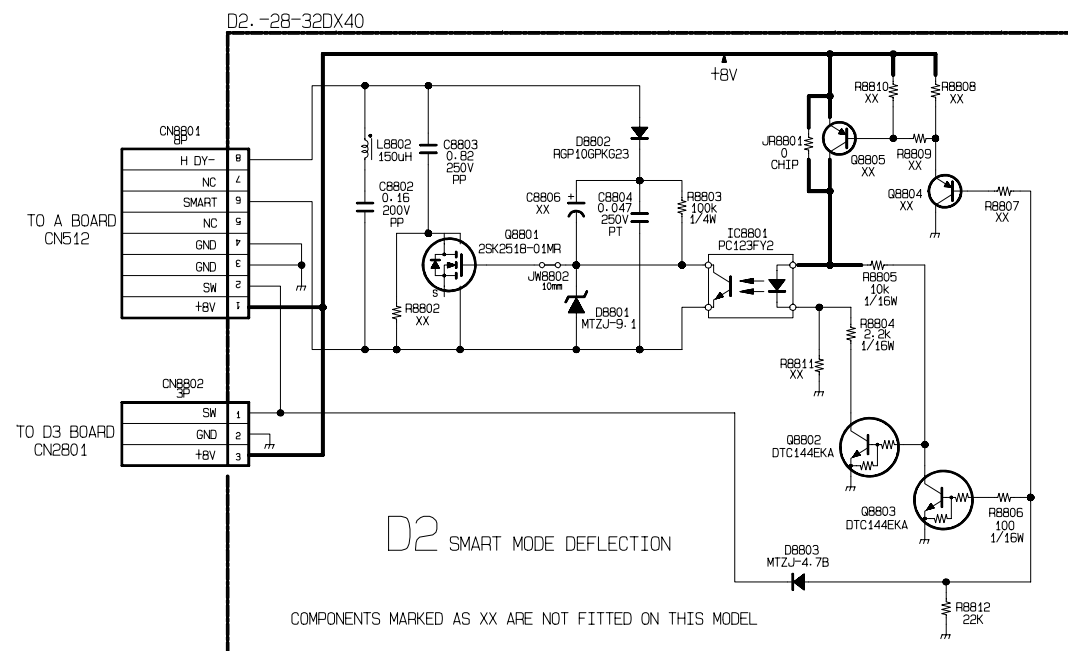

~ F3 Schematic [AC Input, Fuse] ~

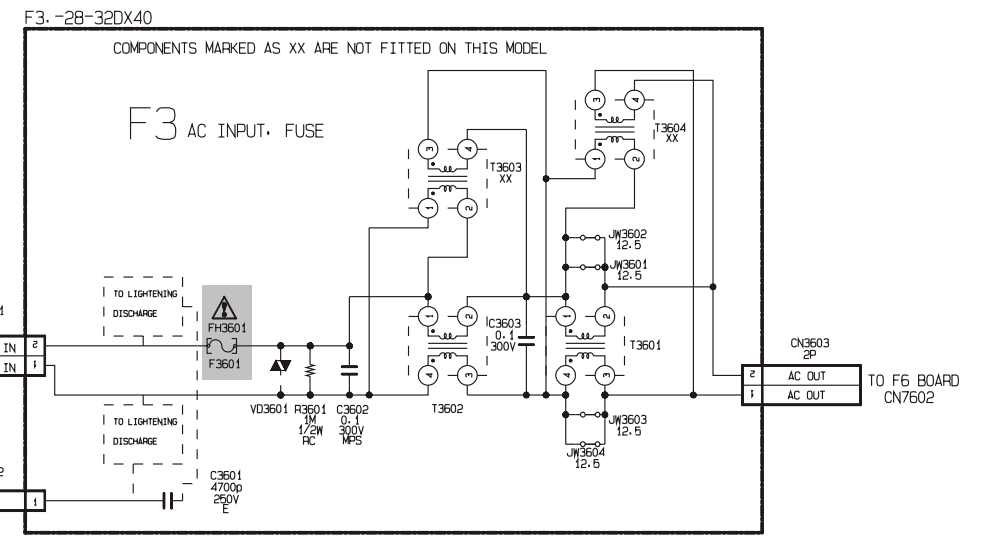

~ F3 Printed Wiring Board ~

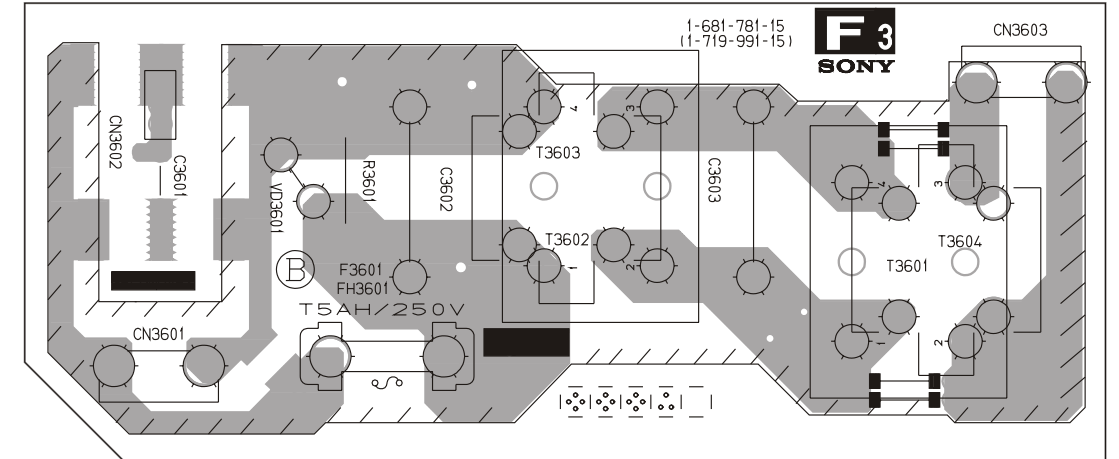

~ F6 Schematic [Power Switch] ~

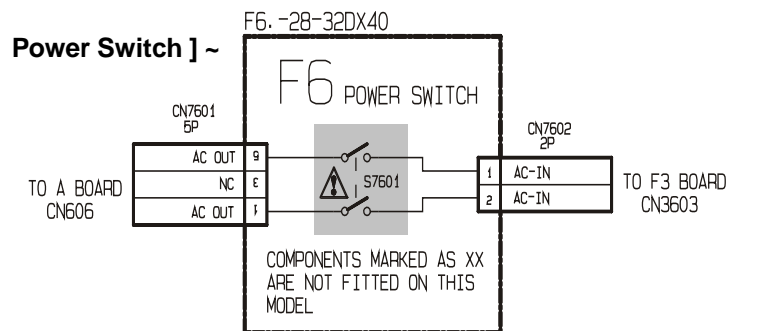

~ F6 Printed Wiring Board ~

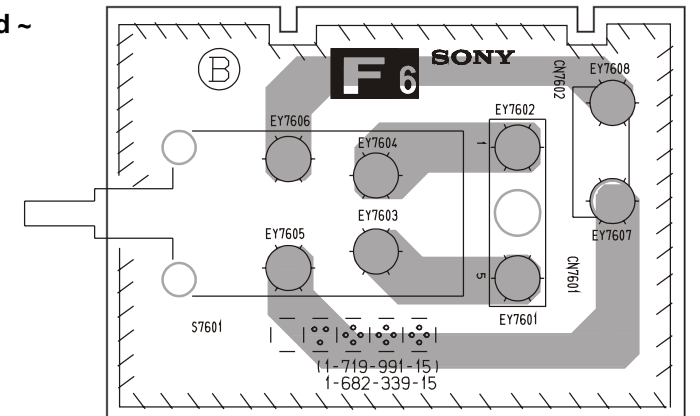

5-4. SEMICONDUCTORS

BA09T
LM2940T-9.0
SE-012N-LF4
UPC2405AHF

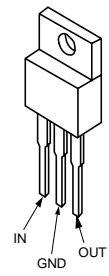

L78L33ABZ-AP

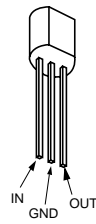

PQ3RF33
PQ05RF11

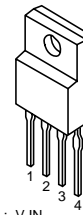

1 : V IN
2 : V OUT
3 : GND
4 : ON/OFF CONTROL

TCET1103G

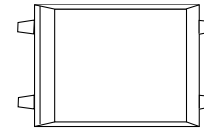

TDA6108JF/N1B

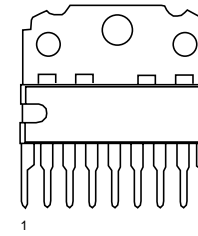

BC327-25



BAS316-115
SARS01V0
DTZ-TT11-6.8B
UDZS-TE17-33B

UDZSTE-175.6B
UDZSTE-176.8B
UDZSTE-179.1B
1SS355TE-17

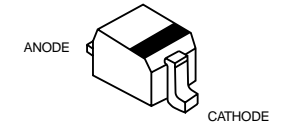

CXA1875AM-T4
MC14053BDR2

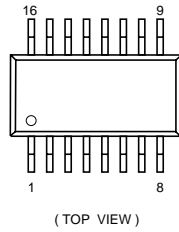

MCZ3001D
TC74HC4066AF

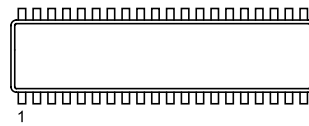

PST573IMT-T1

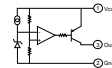
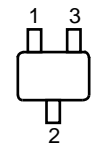

BU2515DX-127



DAN202K

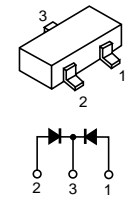

LM358N
LM393DT
LM393N
M5216P
M24C08-WMN6T
TOP209P

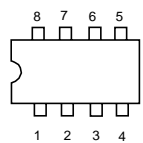

MSP3411G-PP-B8

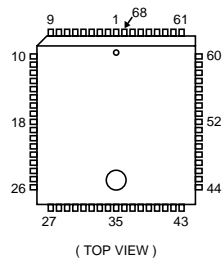

SE135N-LF4

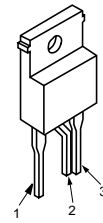

1 V OUT SENSE
2 COLLECTOR
3 GND

TDA7495S

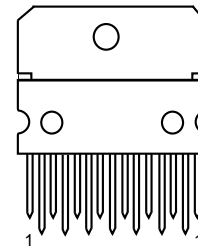

IRF614-037
2SC5511



DTA144EKA-T146
DTA144EKA
DTC114EK
DTC143TKA-T146
DTC144EKA

2SA1037AK-T146-
2SA1162-G
2SC1623-L5L6
2SC3840(3)

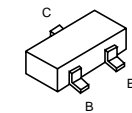

DTC144ESA
KRA104M-AT
KRC104M-AT
2SA1175-HFE
2SA933AS-QT
2SC2785-HFE

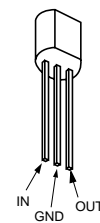

PC123F2

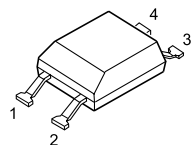

STR-L474-LF428

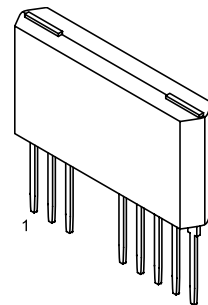

TLP721(D4-G)

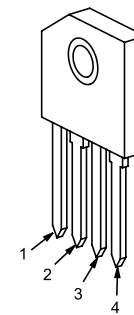

2SD601A-Q-TX

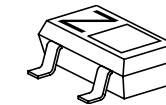

LM393PS-E20
NJM3404AM-T1

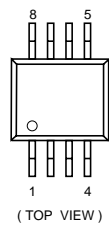

PCF8593/T118



STV9379

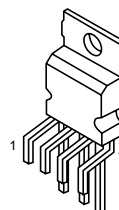

74LVC00-PW
74LVC08APW
74LVC273PW
74LVC32A-PW
74LVC541APW

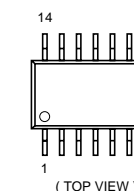

SSK2518-01MR
2SK2640-01MR

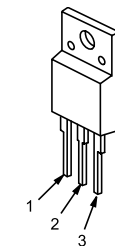

1 GATE
2 DRAIN
3 SOURCE

D1NL20U
D1NL20U-TA
D1NL40-TA2
EGP20G
EL1Z
FUF4005

GP08D
P6KE200ASY
RB721Q
RU-3AM
1SS133T-77
1SS83

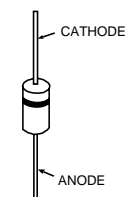

D2SB60A-F04

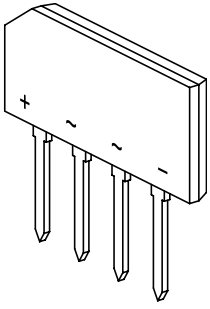

L59SRSGC-CC

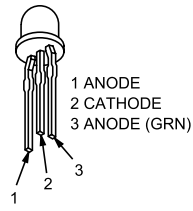

TLG124A

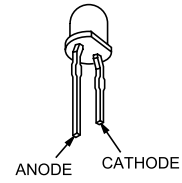

D4SBL20UF1
D4SB60LF
GBU4JL-6088

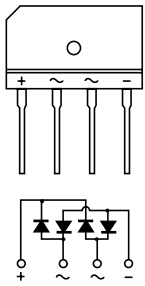

MA3047M-TX

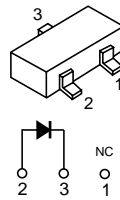

UGB8BT

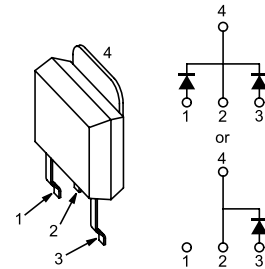

ERA38-06
HZS9-1NB2
MTZJ-4.7C
MTZJ-7.5B
MTZ-33A
MTZJ-T-77-9.1A
RD10ESB2

RD15ES-B2
RD3.6ES-B2
RD5.1ESB2
RD5.6ESB2
RD6.8ES-B2
UZ4.7BSC
1SS119-25

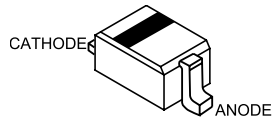

2SA2005

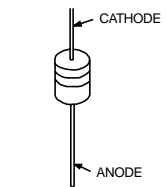
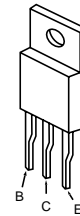

RK14V1

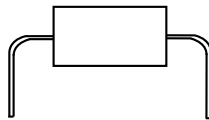

2SB734-34



ERC06-15S

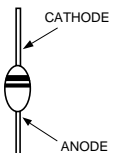

RK46LF-T2
RU4AM-T3

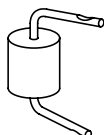

2SK2036(TE85L)

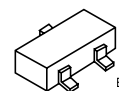

5-5 IC BLOCK DIAGRAMS

A BOARD IC604 BA41W12ST-V5

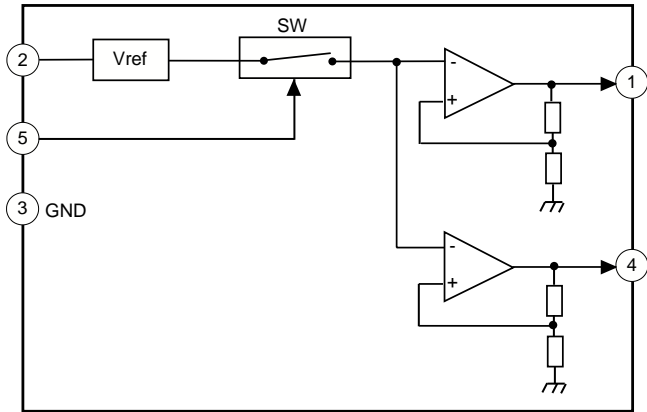

A BOARD IC401/IC531 LM393DT

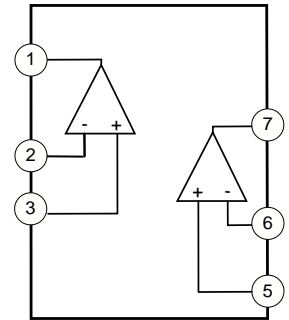

A BOARD IC601 MCZ3001D

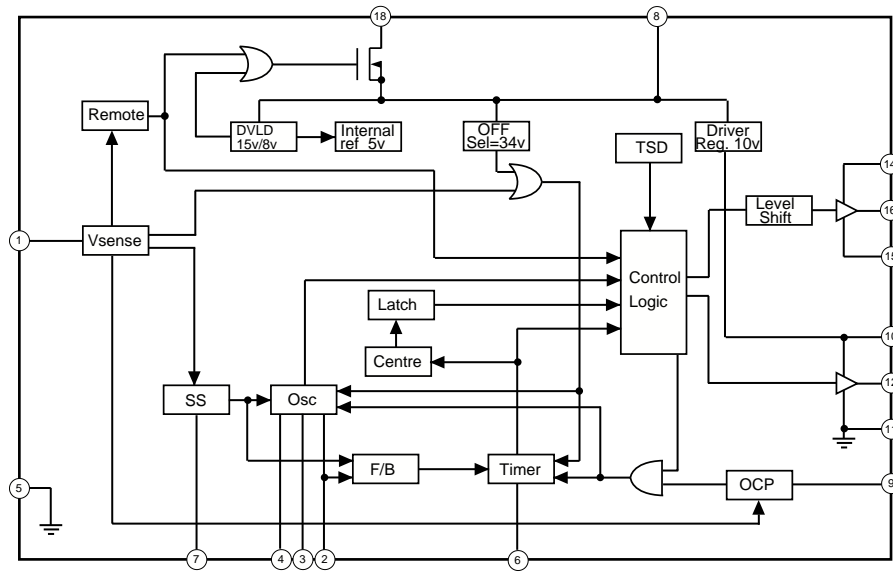

A BOARD IC1201 TDA7495S

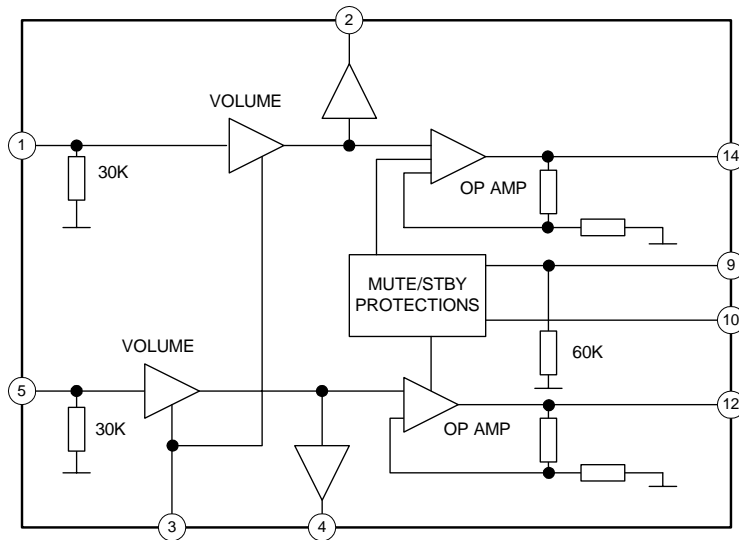

SECTION 6 EXPLODED VIEWS

NOTE :

- Items with no part number and no description are not stocked because they are seldom required for routine service.
- The construction parts of an assembled part are indicated with a collation number in the remarks column.
- Items marked “*” are not stocked since they are seldom required for routine service. Some delay should be anticipated when ordering these items.

6-1. Chassis

Note : Les composants identifiés par une trame et par une marque Δ sont d'une importance critique pour la sécurité. Ne les remplacer que par des pièces du numéro spécifié.

Note : The components identified by shading and marked Δ are critical for safety. Replace only with the part numbers specified in the parts list.

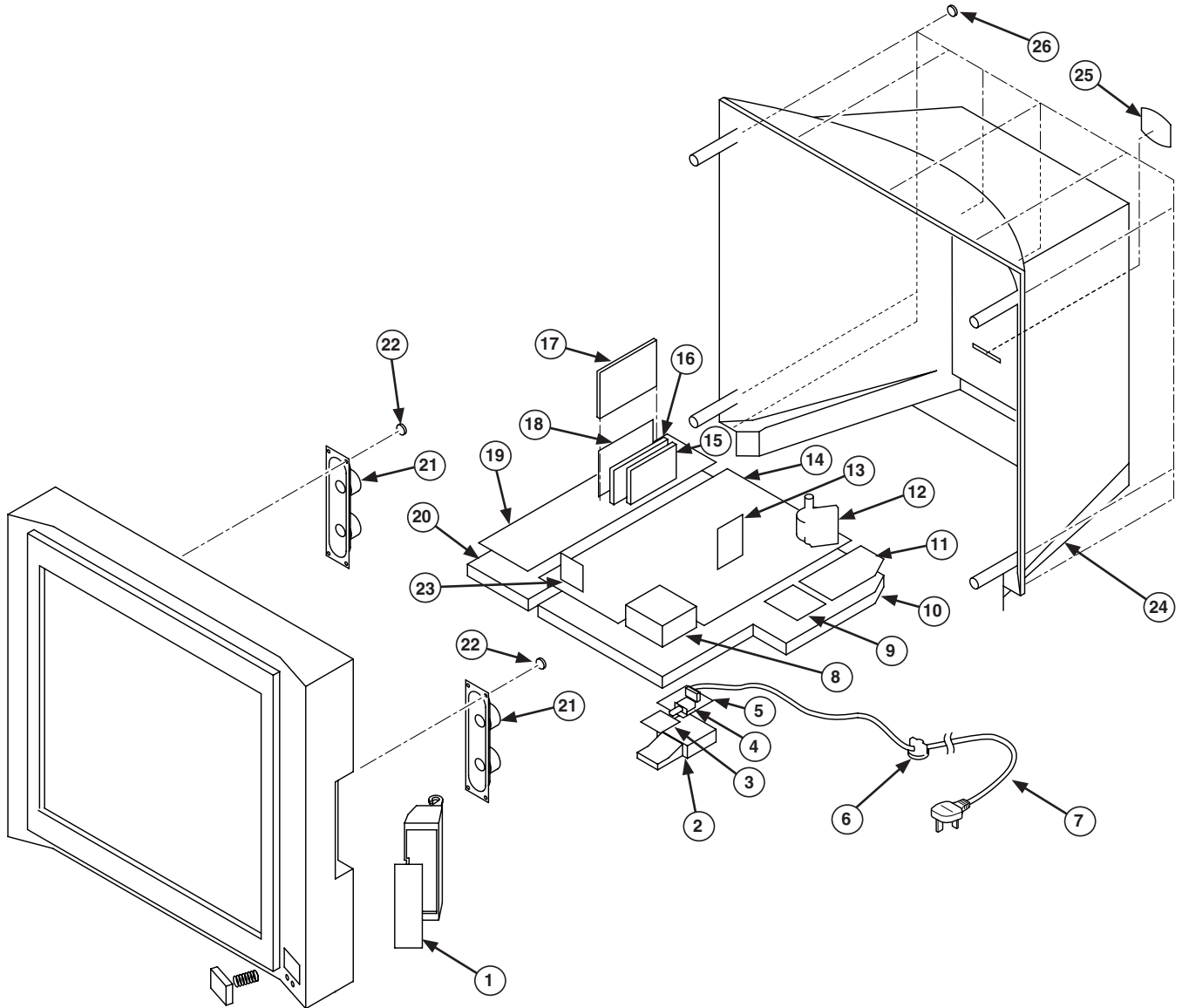

REF.NO.	PART.NO	DESCRIPTION	REMARK	REF.NO.	PART.NO	DESCRIPTION	REMARK
1	*A-1646-242-A	H2 BOARD, COMPLETE		15	1-693-557-13	FRONTEND (TUNER + IF)	
2	*4-205-697-01	H/F BRACKET		16	8-598-585-00	FRONT END BTD-DU604	
3	*A-1646-245-A	H8 BOARD, COMPLETE		17	*4-206-219-01	SHIELD	
4	Δ 1-571-433-21	SWITCH, PUSH (AC POWER)		18	*A-1654-053-A	N BOARD, COMPLETE	
5	*A-1624-106-A	F6 BOARD, COMPLETE		19	*A-1631-157-A	A1 BOARD, COMPLETE	
6	*4-202-531-01	AC CORD LOCK (SC)		20	*4-206-401-01	BRACKET, A1	
7	Δ *1-776-204-12	CORD, POWER (FILTER)		21	1-529-408-11	SPEAKER (4.2x24CM)	
8	1-424-733-11	COIL, PFC CHOKE 65MMH		22	4-384-096-01	SCREW (4x16), TAPPING, +P	
9	*A-1640-431-A	D3 BOARD, COMPLETE		23	*A-1620-146-A	B BOARD, COMPLETE	
10	*4-206-048-11	BRACKET, MAIN		24	4-205-700-21	REAR COVER (KD-28DX40)	
11	*A-1624-109-A	F3 BOARD, COMPLETE			4-205-736-01	REAR COVER (KD-32DX40)	
12	Δ 1-453-308-41	TRANSFORMER ASSY, FLYBACK (NX-4521//Z2B4)		25	4-206-295-01	PCMCIA PLATE	
13	*A-1642-281-A	D2 BOARD, COMPLETE		26	4-039-358-01	SCREW (4x16), (+) BV TAPPING	
14	*A-1632-947-A	A BOARD, COMPLETE (KD-28DX40)					
	*A-1632-948-A	A BOARD, COMPLETE (KD-32DX40)					

6-2. Picture Tube

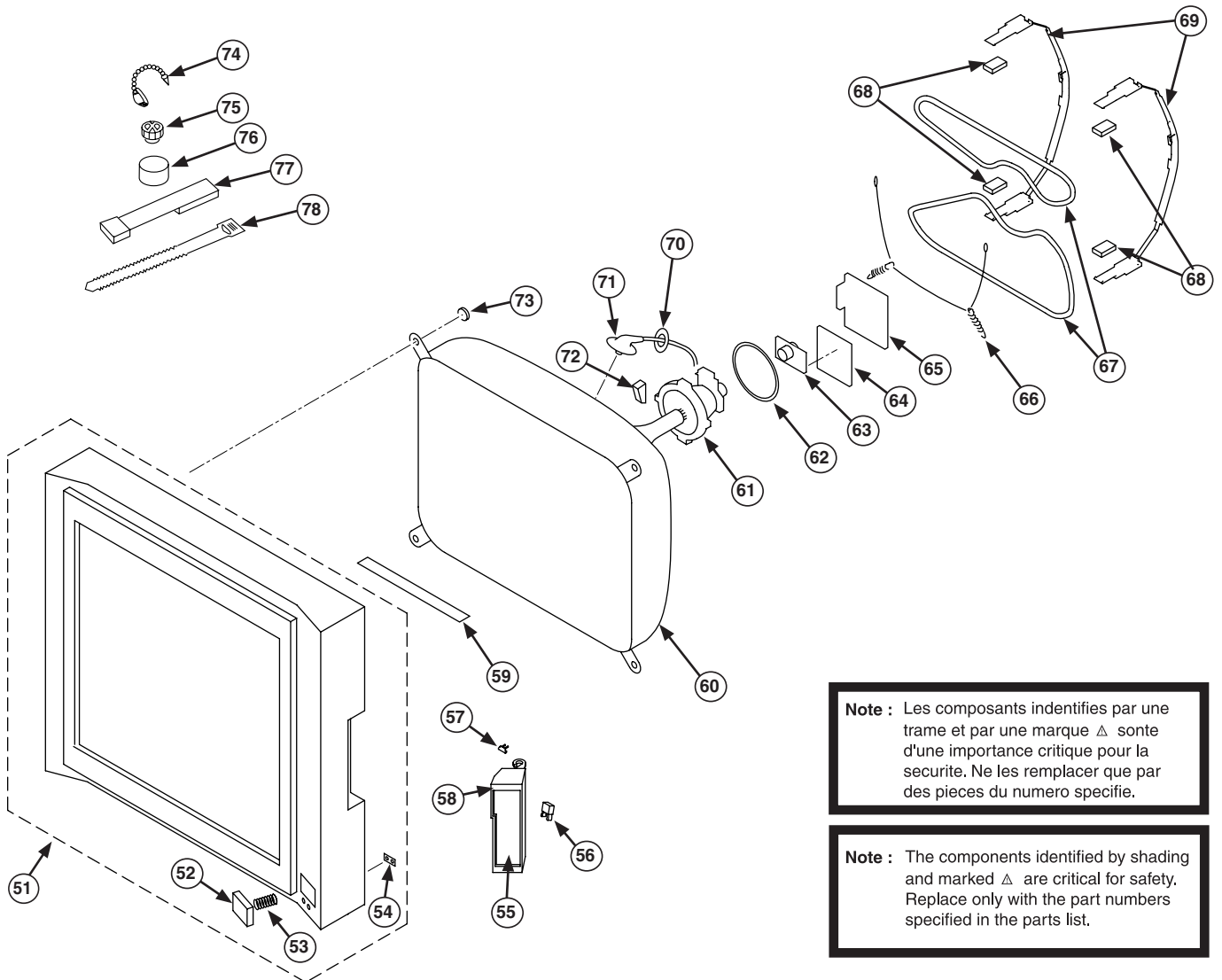

Note : Les composants identifiés par une trame et par une marque Δ sont d'une importance critique pour la sécurité. Ne les remplacer que par des pièces du numéro spécifié.

Note : The components identified by shading and marked Δ are critical for safety. Replace only with the part numbers specified in the parts list.

REF.NO.	PART.NO	DESCRIPTION	REMARK	REF.NO.	PART.NO	DESCRIPTION	REMARK
51	X-4200-630-5	BEZNET ASSY	52-54	65	*A-1638-156-A	C BOARD, COMPLETE	
52	4-205-699-02	POWER BUTTON		66	4-200-433-01	SPRING, EXTENSION	
53	4-202-964-11	SPRING		67	Δ 1-416-466-21	COIL, DEMAGNETIC (KD-28DX40)	
54	4-205-698-01	GUIDE, LIGHT			Δ 1-416-769-11	COIL, DEMAGNETIC (KD-32DX40)	
55	4-205-696-21	DOOR		68	*4-203-390-71	CUSHION, DGC	
56	4-047-464-01	CATCHER, PUSH		69	*4-057-303-01	HOLDER, DGC (KD-28DX40)	
57	4-205-743-01	SPRING, TORSION			*4-059-569-01	HOLDER, DGC (KD-32DX40)	
58	*4-205-695-01	DOOR BRACKET		70	4-202-693-01	HOLDER, HV CABLE	
59	4-203-128-41	SHEET, BLOTTING (KD-28DX40)		71	Δ 1-251-946-11	CAP ASSY, HIGH-VOLTAGE	
	4-203-128-31	SHEET, BLOTTING (KD-32DX40)		72	4-203-658-01	SPACER, DY	
60	Δ 8-737-786-05	PICTURE TUBE (W66LLX060X) (KD-28DX40)		73	4-036-188-01	SCREW, SELF TAPPING (KD-28DX40)	
	Δ 8-735-079-05	PICTURE TUBE (W76LLZ060X) (KD-32DX40)			4-204-225-01	PT SCREW (KD-32DX40)	
61	8-451-521-11	DEFLECTION YOKE (Y28RVC3-B) (KD-28DX40)		74	4-308-870-00	CLIP, LEAD WIRE	
	8-451-520-11	DEFLECTION YOKE (Y32RVC3) (KD-32DX40)		75	1-452-094-00	MAGNET, ROTATABLE DISK; 15MM \emptyset	
62	1-452-896-11	COIL, NA ROTATION (RT200)		76	1-452-032-00	MAGNET, DISK; 10MM \emptyset	
63	8-453-011-11	NECK ASSY, (NA299-M)		77	X-4387-214-1	PERMALLOY ASSY, CORRECTION	
64	*A-1645-050-A	VM BOARD, COMPLETE (KD-28DX40)		78	3-701-007-00	BAND, BINDING	
	*A-1645-049-A	VM BOARD, COMPLETE (KD-32DX40)					

SECTION 7 ELECTRICAL PARTS LIST

PARTS LISTING TABLE OF CONTENTS

	Page
A1 BOARD COMPLETE Parts List :	47
A BOARD COMMON Parts List : Parts common to all models listed in this manual	50
A BOARD VARIANT Parts List : Parts that belong only to the model specified	
Model	
<u>KD-28DX40</u>	57
<u>KD-32DX40</u>	57
B BOARD COMPLETE Parts List :	58
F3 BOARD COMPLETE Parts List :	58
F6 BOARD COMPLETE Parts List :	59
C BOARD COMPLETE Parts List :	59
D3 BOARD COMPLETE Parts List :	59
D2 BOARD COMPLETE Parts List :	60
VM BOARD COMMON Parts List : Parts common to all models listed in this manual	60
VM BOARD VARIANT Parts List : Parts that belong only to the model specified	
Model	
<u>KD-28DX40</u>	62
<u>KD-32DX40</u>	62
H2 BOARD COMPLETE Parts List :	62
H8 BOARD COMPLETE Parts List :	63
MISCELLANEOUS :	64
ACCESSORIES AND PACKAGING MATERIALS :	64

Note: The N Board Schematic Diagram, Printed Wiring Board and Parts List are not indicated in this manual as the PWB is regarded as a non service item for exchange only.

Note : Refer to the designated variant parts list when seeking a part indicated by an asterisk (*) Parts indicated (XX) on the Schematic Diagram are not used in this model and therefore do not appear in the Parts List.

REF.NO.	PART.NO	DESCRIPTION	REMARK	REF.NO.	PART.NO	DESCRIPTION	REMARK
*A-1631-157-A A1 Board, Complete				C4158	1-162-974-11	CERAMIC CHIP 0.01UF	50V
	1-682-341-11	PWB, A1		C4159	1-162-974-11	CERAMIC CHIP 0.01UF	50V
	1-720-213-11	PWB, A1 COMBI		C4160	1-162-974-11	CERAMIC CHIP 0.01UF	50V
	4-202-373-01	SPRING, IC		C4161	1-162-974-11	CERAMIC CHIP 0.01UF	50V
	4-206-218-01	SHIELD BASE		C4162	1-162-974-11	CERAMIC CHIP 0.01UF	50V
	4-206-394-01	HEAT SINK REG		C4163	1-162-974-11	CERAMIC CHIP 0.01UF	50V
	4-382-854-01	SCREW (M3X8), P, SW (+)		C4164	1-162-974-11	CERAMIC CHIP 0.01UF	50V
	< CAPACITOR >			C4165	1-162-974-11	CERAMIC CHIP 0.01UF	50V
C4101	1-164-156-11	CERAMIC CHIP 0.1UF	25V	C4166	1-162-925-11	CERAMIC CHIP 68PF	5.00% 50V
C4102	1-164-156-11	CERAMIC CHIP 0.1UF	25V	C4167	1-162-925-11	CERAMIC CHIP 68PF	5.00% 50V
C4103	1-164-156-11	CERAMIC CHIP 0.1UF	25V	C4601	1-161-964-91	CERAMIC 0.0047UF	250V
C4104	1-162-974-11	CERAMIC CHIP 0.01UF	50V	C4602	1-161-964-91	CERAMIC 0.0047UF	250V
C4105	1-164-156-11	CERAMIC CHIP 0.1UF	25V	C4603	1-137-635-41	ELECT (BLOCK) 68UF	20% 450V
C4107	1-164-156-11	CERAMIC CHIP 0.1UF	25V	C4604	1-127-568-51	CERAMIC 4700PF	10% 2KV
C4108	1-164-156-11	CERAMIC CHIP 0.1UF	25V	C4605	1-126-964-11	ELECT 10UF	20.00% 50V
C4109	1-162-974-11	CERAMIC CHIP 0.01UF	50V	C4606	1-102-228-00	CERAMIC 470PF	10.00% 500V
C4110	1-126-933-11	ELECT 100UF	20.00% 16V	C4607	1-162-318-11	CERAMIC 0.001UF	10.00% 500V
C4111	1-126-933-11	ELECT 100UF	20.00% 16V	C4608	1-165-602-91	CERAMIC 220PF	10 2KV
C4113	1-126-933-11	ELECT 100UF	20.00% 16V	C4609	1-126-967-11	ELECT 47UF	20.00% 50V
C4114	1-126-933-11	ELECT 100UF	20.00% 16V	C4610	1-137-399-11	MYLAR 0.1UF	5.00% 100V
C4115	1-126-933-11	ELECT 100UF	20.00% 16V	C4611	1-137-399-11	MYLAR 0.1UF	5.00% 100V
C4116	1-126-966-11	ELECT 33UF	20.00% 50V	C4612	1-115-766-51	ELECT 0.0022F	20.00% 16V
C4117	1-164-156-11	CERAMIC CHIP 0.1UF	25V	C4613	1-136-165-00	FILM 0.1UF	5.00% 50V
C4118	1-127-715-91	CERAMIC CHIP 0.22UF	10% 16V	C4614	1-104-665-11	ELECT 100UF	20.00% 25V
C4119	1-164-160-11	CERAMIC CHIP 20PF	5.00% 50V	C4615	1-115-766-51	ELECT 0.0022F	20.00% 16V
C4120	1-110-489-11	CAPACITOR 1F	5.5V	C4616	1-136-165-00	FILM 0.1UF	5.00% 50V
C4121	1-127-715-91	CERAMIC CHIP 0.22UF	10% 16V	C4617	1-104-665-11	ELECT 100UF	20.00% 25V
C4126	1-164-346-11	CERAMIC CHIP 1UF	16V	C4618	1-115-792-11	ELECT 0.0022F	20.00% 25V
C4127	1-164-346-11	CERAMIC CHIP 1UF	16V	C4619	1-136-165-00	FILM 0.1UF	5.00% 50V
C4128	1-164-346-11	CERAMIC CHIP 1UF	16V	C4620	1-104-665-11	ELECT 100UF	20.00% 25V
C4130	1-126-964-11	ELECT 10UF	20.00% 50V	C4621	1-136-165-00	FILM 0.1UF	5.00% 50V
C4131	1-164-346-11	CERAMIC CHIP 1UF	16V	C4622	1-104-665-11	ELECT 100UF	20.00% 25V
C4133	1-126-947-11	ELECT 47UF	20.00% 16V	C4623	1-136-165-00	FILM 0.1UF	5.00% 50V
C4134	1-126-947-11	ELECT 47UF	20.00% 16V	C4624	1-104-665-11	ELECT 100UF	20.00% 25V
C4135	1-126-947-11	ELECT 47UF	20.00% 16V	C4625	1-136-165-00	FILM 0.1UF	5.00% 50V
C4136	1-126-947-11	ELECT 47UF	20.00% 16V	C4626	1-104-665-11	ELECT 100UF	20.00% 25V
C4137	1-126-964-11	ELECT 10UF	20.00% 50V	C4627	1-136-165-00	FILM 0.1UF	5.00% 50V
C4138	1-164-156-11	CERAMIC CHIP 0.1UF	25V	C4628	1-104-665-11	ELECT 100UF	20.00% 25V
C4139	1-164-156-11	CERAMIC CHIP 0.1UF	25V	C4629	1-136-165-00	FILM 0.1UF	5.00% 50V
C4142	1-126-964-11	ELECT 10UF	20.00% 50V	C4630	1-164-346-11	CERAMIC CHIP 1UF	16V
C4146	1-126-947-11	ELECT 47UF	20.00% 16V	C4631	1-164-156-11	CERAMIC CHIP 0.1UF	25V
C4147	1-164-156-11	CERAMIC CHIP 0.1UF	25V	C4632	1-126-964-11	ELECT 10UF	20.00% 50V
C4148	1-162-974-11	CERAMIC CHIP 0.01UF	50V	C4633	1-164-156-11	CERAMIC CHIP 0.1UF	25V
C4149	1-164-156-11	CERAMIC CHIP 0.1UF	25V	< CONNECTOR >			
C4150	1-126-966-11	ELECT 33UF	20.00% 50V	CN4101	*1-794-730-11	SOCKET, PC CONNECTOR (PC BOARD)	
C4151	1-126-969-11	ELECT 220UF	20.00% 50V	CN4103	*1-564-509-11	PLUG, CONNECTOR 6P	
C4152	1-164-156-11	CERAMIC CHIP 0.1UF	25V	CN4104	*1-564-596-11	PLUG, CONNECTOR 15P	
C4157	1-162-974-11	CERAMIC CHIP 0.01UF	50V	CN4601	1-580-843-11	PIN, CONNECTOR (POWER)	
				CN4602	*1-564-506-11	PLUG, CONNECTOR 3P	

Note : The components identified by shading and marked Δ are critical for safety. Replace only with the part numbers specified in the parts list.

A1

REF.NO.	PART.NO	DESCRIPTION	REMARK	REF.NO.	PART.NO	DESCRIPTION	REMARK
	< DIODE >			IC4602	Δ 8-749-013-21	IC TLP721 (D4-G)	
D4101	8-719-982-24	DIODE MTZJ-33A		IC4603	6-700-293-01	IC SE-012N-LF4	
D4102	8-719-812-43	DIODE TLG124A		IC4604	8-759-390-57	IC UPC2405AHF	
D4103	8-719-914-43	DIODE DAN202K		IC4605	8-759-069-28	IC PQ05RF11	
D4601	8-719-025-88	DIODE GBU4JL-6088		IC4606	8-759-267-25	IC LM2940T-9.0	
D4602	8-719-080-26	DIODE SARS01V0		IC4607	8-759-473-67	IC PQ3RF33	
D4603	8-719-075-11	DIODE AG01ZV0		IC4608	8-759-988-13	IC LM393PS	
D4604	8-719-075-11	DIODE AG01ZV0			< COIL >		
D4605	8-719-075-11	DIODE AG01ZV0		L4101	1-410-667-31	INDUCTOR	22UH
D4606	8-719-075-11	DIODE AG01ZV0		L4102	1-412-002-31	INDUCTOR	4.7UH
D4607	6-500-081-01	DIODE RK34-LF-C4		L4103	1-412-002-31	INDUCTOR	4.7UH
D4608	8-719-059-21	DIODE RK46LF-T2		L4600	1-410-397-21	FERRITE	1.1UH
D4609	6-500-082-01	DIODE RJ43-LF-T2		L4602	1-412-519-11	INDUCTOR	3.3UH
D4610	8-719-076-73	DIODE UGB8BT		L4603	1-412-519-11	INDUCTOR	3.3UH
D4611	8-719-991-33	DIODE 1SS133T-77		L4604	1-412-519-11	INDUCTOR	3.3UH
D4612	8-719-076-73	DIODE UGB8BT			< IC LINK >		
D4613	8-719-401-32	DIODE MA3047M-TX		PS4601	1-535-465-11	LEAD, JUMPER (5.0MM)	
	< FERRITE BEAD >			PS4603	Δ 1-801-550-21	PROTECTOR, MODULE	
FB4103	1-469-869-21	FERRITE	0UH	PS4604	1-535-465-11	LEAD, JUMPER (5.0MM)	
FB4104	1-469-869-21	FERRITE	0UH	PS4605	Δ 1-801-549-21	PROTECTOR, MODULE	
FB4105	1-469-869-21	FERRITE	0UH		< TRANSISTOR >		
FB4106	1-469-869-21	FERRITE	0UH	Q4101	1-801-806-11	TRANSISTOR DTC144EKA	
FB4107	1-469-869-21	FERRITE	0UH	Q4102	1-801-806-11	TRANSISTOR DTC144EKA	
FB4108	1-469-869-21	FERRITE	0UH	Q4103	1-801-806-11	TRANSISTOR DTC144EKA	
FB4109	1-469-869-21	FERRITE	0UH	Q4104	8-729-028-28	TRANSISTOR 2SK2036 (TE85L)	
FB4110	1-469-869-21	FERRITE	0UH	Q4105	8-729-028-28	TRANSISTOR 2SK2036 (TE85L)	
FB4111	1-469-869-21	FERRITE	0UH	Q4106	8-729-028-28	TRANSISTOR 2SK2036 (TE85L)	
FB4601	1-535-465-11	LEAD, JUMPER	(5.0MM)	Q4107	8-729-028-28	TRANSISTOR 2SK2036 (TE85L)	
FB4602	1-535-465-11	LEAD, JUMPER	(5.0MM)	Q4112	8-729-216-22	TRANSISTOR 2SA1162-G	
FB4603	1-410-396-41	FERRITE	0.45UH	Q4113	8-729-216-22	TRANSISTOR 2SA1162-G	
FB4604	1-535-465-11	LEAD, JUMPER	(5.0MM)	Q4114	8-729-216-22	TRANSISTOR 2SA1162-G	
FB4605	1-410-396-41	FERRITE	0.45UH	Q4115	8-729-216-22	TRANSISTOR 2SA1162-G	
FB4606	1-410-396-41	FERRITE	0.45UH	Q4116	8-729-216-22	TRANSISTOR 2SA1162-G	
	< FILTER >			Q4117	8-729-216-22	TRANSISTOR 2SA1162-G	
FL4101	1-239-899-21	FILTER, CHIP EMI		Q4118	1-801-806-11	TRANSISTOR DTC144EKA	
FL4102	1-239-899-21	FILTER, CHIP EMI		Q4119	1-801-806-11	TRANSISTOR DTC144EKA	
FL4103	1-239-899-21	FILTER, CHIP EMI		Q4120	1-801-806-11	TRANSISTOR DTC144EKA	
FL4104	1-239-899-21	FILTER, CHIP EMI		Q4123	8-729-216-22	TRANSISTOR 2SA1162-G	
FL4105	1-239-899-21	FILTER, CHIP EMI		Q4124	8-729-216-22	TRANSISTOR 2SA1162-G	
FL4108	1-239-899-21	FILTER, CHIP EMI		Q4601	8-729-119-78	TRANSISTOR 2SC2785-HFE	
	< IC >			Q4602	1-801-806-11	TRANSISTOR DTC144EKA	
IC4101	8-759-239-25	IC TC74HC4066AF		Q4603	1-801-806-11	TRANSISTOR DTC144EKA	
IC4102	8-759-478-44	IC PCF8593/T118			< RESISTOR >		
IC4104	8-759-385-77	IC MC14053 BDR2		R4101	1-216-864-11	SHORT	0
IC4105	8-752-072-94	IC CXA1875AM-T4		R4103	1-216-821-11	RES-CHIP	1K 5% 1/16W
IC4601	6-700-292-01	IC STR-L474-LF428					

REF.NO.	PART.NO	DESCRIPTION	REMARK	REF.NO.	PART.NO	DESCRIPTION	REMARK
R4104	1-216-864-11	SHORT	0	R4167	1-216-833-11	RES-CHIP	10K 5% 1/16W
R4105	1-216-864-11	SHORT	0	R4168	1-216-829-11	RES-CHIP	4.7K 5% 1/16W
R4106	1-216-864-11	SHORT	0	R4169	1-216-821-11	RES-CHIP	1K 5% 1/16W
R4107	1-216-864-11	SHORT	0	R4170	1-216-833-11	RES-CHIP	10K 5% 1/16W
R4108	1-216-864-11	SHORT	0	R4171	1-216-821-11	RES-CHIP	1K 5% 1/16W
R4109	1-216-864-11	SHORT	0	R4172	1-216-833-11	RES-CHIP	10K 5% 1/16W
R4110	1-216-864-11	SHORT	0	R4173	1-216-833-11	RES-CHIP	10K 5% 1/16W
R4111	1-216-864-11	SHORT	0	R4176	1-216-829-11	RES-CHIP	4.7K 5% 1/16W
R4112	1-216-864-11	SHORT	0	R4177	1-216-821-11	RES-CHIP	1K 5% 1/16W
R4113	1-216-864-11	SHORT	0	R4178	1-216-829-11	RES-CHIP	4.7K 5% 1/16W
R4114	1-216-864-11	SHORT	0	R4183	1-216-809-11	RES-CHIP	100 5% 1/16W
R4115	1-216-864-11	SHORT	0	R4184	1-216-809-11	RES-CHIP	100 5% 1/16W
R4116	1-216-821-11	RES-CHIP	1K 5% 1/16W	R4185	1-216-821-11	RES-CHIP	1K 5% 1/16W
R4118	1-216-864-11	SHORT	0	R4186	1-216-841-11	RES-CHIP	47K 5% 1/16W
R4119	1-216-864-11	SHORT	0	R4187	1-216-833-11	RES-CHIP	10K 5% 1/16W
R4120	1-216-864-11	SHORT	0	R4188	1-216-841-11	RES-CHIP	47K 5% 1/16W
R4121	1-216-864-11	SHORT	0	R4189	1-216-833-11	RES-CHIP	10K 5% 1/16W
R4123	1-216-817-11	RES-CHIP	470 5% 1/16W	R4190	1-216-864-11	SHORT	0
R4124	1-216-841-11	RES-CHIP	47K 5% 1/16W	R4195	1-216-809-11	RES-CHIP	100 5% 1/16W
R4125	1-216-821-11	RES-CHIP	1K 5% 1/16W	R4196	1-216-809-11	RES-CHIP	100 5% 1/16W
R4128	1-216-821-11	RES-CHIP	1K 5% 1/16W	R4199	1-216-825-11	RES-CHIP	2.2K 5% 1/16W
R4129	1-216-821-11	RES-CHIP	1K 5% 1/16W	R4201	1-216-833-11	RES-CHIP	10K 5% 1/16W
R4130	1-216-829-11	RES-CHIP	4.7K 5% 1/16W	R4202	1-216-864-11	SHORT	0
R4131	1-216-829-11	RES-CHIP	4.7K 5% 1/16W	R4204	1-216-864-11	SHORT	0
R4132	1-216-833-11	RES-CHIP	10K 5% 1/16W	R4206	1-216-821-11	RES-CHIP	1K 5% 1/16W
R4133	1-216-833-11	RES-CHIP	10K 5% 1/16W	R4601	1-217-155-00	METAL	1 10% 2W
R4136	1-216-841-11	RES-CHIP	47K 5% 1/16W	R4602	1-260-128-91	CARBON	270K 5% 1/2W
R4137	1-216-809-11	RES-CHIP	100 5% 1/16W	R4603	1-217-418-00	FUSIBLE	0.47 10% 1/2W
R4138	1-216-809-11	RES-CHIP	100 5% 1/16W	R4604	1-260-133-11	CARBON	680K 5% 1/2W
R4139	1-216-809-11	RES-CHIP	100 5% 1/16W	R4605	1-215-884-11	METAL OXIDE	47 5% 2W
R4140	1-216-833-11	RES-CHIP	10K 5% 1/16W	R4606	1-249-401-11	CARBON	47 5% 1/4W
R4141	1-216-833-11	RES-CHIP	10K 5% 1/16W	R4607	1-249-421-11	CARBON	2.2K 5% 1/4W
R4142	1-216-833-11	RES-CHIP	10K 5% 1/16W	R4608	1-249-415-11	CARBON	680 5% 1/4W
R4143	1-216-833-11	RES-CHIP	10K 5% 1/16W	R4609	1-216-366-00	METAL OXIDE	0.56 5% 2W
R4144	1-216-864-11	SHORT	0	R4610	1-247-835-91	CARBON	1.5K 5% 1/4W
R4145	1-216-864-11	SHORT	0	R4611	1-249-403-11	CARBON	68 5% 1/4W
R4151	1-216-821-11	RES-CHIP	1K 5% 1/16W	R4612	1-249-418-11	CARBON	1.2K 5% 1/4W
R4152	1-216-835-11	RES-CHIP	15K 5% 1/16W	R4613	1-249-419-11	CARBON	1.5K 5% 1/4W
R4153	1-216-833-11	RES-CHIP	10K 5% 1/16W	R4614	1-247-807-31	CARBON	100 5% 1/4W
R4155	1-216-821-11	RES-CHIP	1K 5% 1/16W	R4616	1-249-437-11	CARBON	47K 5% 1/4W
R4156	1-216-835-11	RES-CHIP	15K 5% 1/16W	R4617	1-249-437-11	CARBON	47K 5% 1/4W
R4157	1-216-833-11	RES-CHIP	10K 5% 1/16W	R4618	1-216-825-11	RES-CHIP	2.2K 5% 1/16W
R4158	1-216-864-11	SHORT	0	R4619	1-216-825-11	RES-CHIP	2.2K 5% 1/16W
R4160	1-216-841-11	RES-CHIP	47K 5% 1/16W	R4620	1-216-825-11	RES-CHIP	2.2K 5% 1/16W
R4161	1-216-829-11	RES-CHIP	4.7K 5% 1/16W	R4621	1-216-823-11	RES-CHIP	1.5K 5% 1/16W
R4162	1-216-841-11	RES-CHIP	47K 5% 1/16W	R4622	1-216-825-11	RES-CHIP	2.2K 5% 1/16W
R4163	1-216-829-11	RES-CHIP	4.7K 5% 1/16W	R4623	1-216-821-11	RES-CHIP	1K 5% 1/16W
R4164	1-216-841-11	RES-CHIP	47K 5% 1/16W	R4624	1-216-809-11	RES-CHIP	100 5% 1/16W
R4165	1-216-833-11	RES-CHIP	10K 5% 1/16W	R4625	1-260-127-11	CARBON	220K 5% 1/2W
R4166	1-216-841-11	RES-CHIP	47K 5% 1/16W	R4626	1-247-837-91	CARBON	1.8K 5% 1/4W

Note : The components identified by shading and marked Δ are critical for safety. Replace only with the part numbers specified in the parts list.

A1 **A**

REF.NO.	PART.NO	DESCRIPTION	REMARK	REF.NO.	PART.NO	DESCRIPTION	REMARK
		< RELAY >					
RY4601	Δ 1-755-388-11	RELAY (AC POWER)		C038	1-163-038-91	CERAMIC CHIP 0.1UF	25V
		< TRANSFORMER >		C039	1-164-505-11	CERAMIC CHIP 2.2UF	16V
T4601	Δ 1-437-445-11	TRANSFORMER, CONVERTER (SRT)		C040	1-163-017-00	CERAMIC CHIP 0.0047UF	10.00% 50V
T4602	1-424-993-11	PFC CHOKE COIL 20MH		C042	1-162-625-11	CERAMIC CHIP 0.0047UF	5.00% 50V
		< TUNER >		C043	1-163-037-11	CERAMIC CHIP 0.022UF	10.00% 50V
TU4101	8-598-585-00	FRONT END BTD-DU604		C044	1-164-346-11	CERAMIC CHIP 1UF	16V
TU4102	1-693-557-13	FRONTEND (TUNER+IF)		C045	1-164-489-11	CERAMIC CHIP 0.22UF	10.00% 16V
		< CRYSTAL >		C046	1-163-037-11	CERAMIC CHIP 0.022UF	10.00% 50V
X4101	1-760-105-11	VIBRATOR, CRYSTAL		C047	1-126-935-11	ELECT 470UF	20.00% 16V
		*A-1632-947-A A Board, Complete (KD-28DX40)		C053	1-164-004-11	CERAMIC CHIP 0.1UF	10.00% 25V
		*A-1632-948-A A Board, Complete (KD-32DX40)		C055	1-126-960-11	ELECT 1UF	20.00% 50V
		A Board Common Parts		C100	1-126-933-11	ELECT 100UF	20.00% 16V
		4-382-854-01 SCREW (M3X8), P, SW (+)		C103	1-126-965-91	ELECT 22UF	20.00% 50V
		4-382-854-01 SCREW (M3X8), P, SW (+)		C105	1-162-970-91	CERAMIC CHIP 0.01UF	10.00% 25V
		< CAPACITOR >		C106	1-126-933-11	ELECT 100UF	20.00% 16V
C002	1-163-233-91	CERAMIC CHIP 18PF	5.00% 50V	C112	1-162-970-91	CERAMIC CHIP 0.01UF	10.00% 25V
C004	1-163-037-11	CERAMIC CHIP 0.022UF	10.00% 50V	C204	1-115-340-11	CERAMIC CHIP 0.22UF	10.00% 25V
C005	1-126-916-11	ELECT 1000UF	20.00% 6.3V	C211	1-162-970-91	CERAMIC CHIP 0.01UF	10.00% 25V
C006	1-163-233-91	CERAMIC CHIP 18PF	5.00% 50V	C213	1-163-249-11	CERAMIC CHIP 82PF	5.00% 50V
C009	1-164-004-11	CERAMIC CHIP 0.1UF	10.00% 25V	C214	1-163-139-00	CERAMIC CHIP 820PF	5.00% 50V
C010	1-164-005-11	CERAMIC CHIP 0.47UF	16V	C215	1-163-084-00	CERAMIC CHIP 1.5PF	0.25PF 50V
C011	1-163-005-91	CERAMIC CHIP 470PF	10.00% 50V	C216	1-163-117-00	CERAMIC CHIP 100PF	5.00% 50V
C012	1-126-963-11	ELECT 4.7UF	20.00% 50V	C217	1-163-084-00	CERAMIC CHIP 1.5PF	0.25PF 50V
C013	1-162-970-91	CERAMIC CHIP 0.01UF	10.00% 25V	C218	1-163-249-11	CERAMIC CHIP 82PF	5.00% 50V
C014	1-162-970-91	CERAMIC CHIP 0.01UF	10.00% 25V	C221	1-163-109-00	CERAMIC CHIP 47PF	5.00% 50V
C015	1-162-970-91	CERAMIC CHIP 0.01UF	10.00% 25V	C222	1-163-117-00	CERAMIC CHIP 100PF	5.00% 50V
C016	1-216-295-91	SHORT 0		C223	1-126-965-91	ELECT 22UF	20.00% 50V
C018	1-162-970-91	CERAMIC CHIP 0.01UF	10.00% 25V	C224	1-163-117-00	CERAMIC CHIP 100PF	5.00% 50V
C019	1-162-919-11	CERAMIC CHIP 22PF	5.00% 50V	C225	1-126-157-11	ELECT 10UF	20.00% 16V
C020	1-164-004-11	CERAMIC CHIP 0.1UF	10.00% 25V	C226	1-164-004-11	CERAMIC CHIP 0.1UF	10.00% 25V
C021	1-163-037-11	CERAMIC CHIP 0.022UF	10.00% 50V	C227	1-163-117-00	CERAMIC CHIP 100PF	5.00% 50V
C022	1-126-935-11	ELECT 470UF	20.00% 10V	C228	1-126-965-91	ELECT 22UF	20.00% 50V
C025	1-126-935-11	ELECT 470UF	20.00% 16V	C229	1-163-017-00	CERAMIC CHIP 0.0047UF	10.00% 50V
C026	1-162-970-91	CERAMIC CHIP 0.01UF	10.00% 25V	C230	1-164-336-11	CERAMIC CHIP 0.33UF	25V
C027	1-164-004-11	CERAMIC CHIP 0.1UF	10.00% 25V	C232	1-126-157-11	ELECT 10UF	20.00% 16V
C028	1-163-009-91	CERAMIC CHIP 0.001UF	10.00% 50V	C233	1-164-004-11	CERAMIC CHIP 0.1UF	10.00% 25V
C030	1-163-009-91	CERAMIC CHIP 0.001UF	10.00% 50V	C234	1-107-823-11	CERAMIC CHIP 0.47UF	10.00% 16V
C033	1-163-009-91	CERAMIC CHIP 0.001UF	10.00% 50V	C235	1-164-005-11	CERAMIC CHIP 0.47UF	25V
C035	1-163-009-91	CERAMIC CHIP 0.001UF	10.00% 50V	C236	1-126-157-11	ELECT 10UF	20.00% 16V
C036	1-163-009-91	CERAMIC CHIP 0.001UF	10.00% 50V	C237	1-126-965-91	ELECT 22UF	20.00% 50V
C037	1-136-244-11	FILM 0.1UF	2.00% 50V	C238	1-163-117-00	CERAMIC CHIP 100PF	5.00% 50V
				C239	1-126-157-11	ELECT 10UF	20.00% 16V
				C242	1-163-009-91	CERAMIC CHIP 0.001UF	10.00% 50V
				C245	1-163-009-91	CERAMIC CHIP 0.001UF	10.00% 50V
				C401	1-126-964-11	ELECT 10UF	20.00% 50V
				C404	1-162-970-91	CERAMIC CHIP 0.01UF	10.00% 25V
				C405	1-163-009-91	CERAMIC CHIP 0.001UF	10.00% 50V
				C407	1-164-346-11	CERAMIC CHIP 1UF	16V
				C408	1-127-715-91	CERAMIC CHIP 0.22UF	10% 16V
				C409	1-126-964-11	ELECT 10UF	20.00% 50V

Note : The components identified by shading and marked Δ are critical for safety. Replace only with the part numbers specified in the parts list.

A

REF.NO.	PART.NO	DESCRIPTION	REMARK	REF.NO.	PART.NO	DESCRIPTION	REMARK
C410	1-162-970-91	CERAMIC CHIP 0.01UF	10.00% 25V	C550	1-107-638-11	ELECT 33UF	20.00% 160V
C411	1-163-009-91	CERAMIC CHIP 0.001UF	10.00% 50V	C552	1-102-212-00	CERAMIC 820PF	10.00% 500V
C412	1-164-346-11	CERAMIC CHIP 1UF	16V	C553	1-137-417-11	MYLAR 0.0047UF	10.00% 200V
C414	1-164-346-11	CERAMIC CHIP 1UF	16V	C580	1-162-970-91	CERAMIC CHIP 0.01UF	10.00% 25V
C415	1-164-346-11	CERAMIC CHIP 1UF	16V	C582	1-163-259-91	CERAMIC CHIP 220PF	5.00% 50V
C416	1-126-964-11	ELECT 10UF	20.00% 50V	C583	1-163-009-91	CERAMIC CHIP 0.001UF	10.00% 50V
C417	1-162-970-91	CERAMIC CHIP 0.01UF	10.00% 25V	C600	1-119-888-51	CERAMIC 2200PF	20.00% 250V
C418	1-164-346-11	CERAMIC CHIP 1UF	16V	C601	Δ 1-136-516-12	FILM 0.1UF	20.00% 300V
C419	1-162-964-11	CERAMIC CHIP 0.001UF	10.00% 50V	C602	Δ 1-136-516-12	FILM 0.1UF	20.00% 300V
C423	1-127-715-91	CERAMIC CHIP 0.22UF	10% 16V	C603	Δ 1-119-889-51	CERAMIC 1000PF	10.00% 250V
C424	1-163-009-91	CERAMIC CHIP 0.001UF	10.00% 50V	C604	Δ 1-119-889-51	CERAMIC 1000PF	10.00% 250V
C426	1-163-009-91	CERAMIC CHIP 0.001UF	10.00% 50V	C605	1-115-785-11	ELECT 470UF	20.00% 16V
C427	1-163-009-91	CERAMIC CHIP 0.001UF	10.00% 50V	C606	1-117-751-11	ELECT (BLOCK) 220UF	20.00% 450V
C428	1-163-009-91	CERAMIC CHIP 0.001UF	10.00% 50V	C607	1-126-964-11	ELECT 10UF	20.00% 50V
C429	1-163-009-91	CERAMIC CHIP 0.001UF	10.00% 50V	C608	1-126-963-11	ELECT 4.7UF	20.00% 50V
C430	1-102-114-00	CERAMIC 470PF	10.00% 50V	C610	1-126-941-11	ELECT 470UF	20.00% 25V
C435	1-163-017-00	CERAMIC CHIP 0.0047UF	10.00% 50V	C611	1-163-009-91	CERAMIC CHIP 0.001UF	10.00% 50V
C436	1-163-017-00	CERAMIC CHIP 0.0047UF	10.00% 50V	C612	1-104-571-91	CERAMIC 0.0015UF	10.00% 2KV
C437	1-164-346-11	CERAMIC CHIP 1UF	16V	C613	1-104-571-91	CERAMIC 0.0015UF	10.00% 2KV
C438	1-164-346-11	CERAMIC CHIP 1UF	16V	C614	1-161-964-51	CERAMIC 0.0047UF	250V
C445	1-126-964-11	ELECT 10UF	20.00% 50V	C615	1-115-339-11	CERAMIC CHIP 0.1UF	10.00% 50V
C446	1-126-964-11	ELECT 10UF	20.00% 50V	C616	1-165-127-11	CERAMIC 470PF	10.00% 500V
C447	1-162-970-91	CERAMIC CHIP 0.01UF	10.00% 25V	C617	1-165-127-11	CERAMIC 470PF	10.00% 500V
C449	1-216-025-11	RES-CHIP 100 5%	1/10W	C618	1-126-949-11	ELECT 220UF	20.00% 35V
C501	1-126-968-11	ELECT 100UF	20.00% 50V	C619	1-165-127-51	CERAMIC 470PF	10.00% 500V
C502	1-163-038-91	CERAMIC CHIP 0.1UF	25V	C620	1-137-990-21	FILM 33000PF	3% 800V
C503	1-115-832-11	ELECT 100UF	20.00% 50V	C621	1-165-127-51	CERAMIC 470PF	10.00% 500V
C504	1-106-220-00	MYLAR 0.1UF	10.00% 100V	C622	1-104-571-91	CERAMIC 0.0015UF	10.00% 2KV
C505	1-137-194-81	FILM 0.47UF	5.00% 50V	C623	1-104-571-91	CERAMIC 0.0015UF	10.00% 2KV
C506	1-162-970-91	CERAMIC CHIP 0.01UF	10.00% 25V	C624	1-126-935-11	ELECT 470UF	20.00% 16V
C509	1-107-364-11	MYLAR 0.01UF	10.00% 400V	C626	1-126-967-11	ELECT 47UF	20.00% 50V
C510	1-163-005-91	CERAMIC CHIP 470PF	10.00% 50V	C627	1-126-964-11	ELECT 10UF	20.00% 50V
C513	1-107-662-11	ELECT 22UF	20.00% 250V	C628	1-126-963-11	ELECT 4.7UF	20.00% 50V
C515	1-104-666-11	ELECT 220UF	20.00% 25V	C629	1-165-127-11	CERAMIC 470PF	10.00% 500V
C517	1-115-781-11	ELECT 220UF	20.00% 25V	C630	1-107-641-11	ELECT 220UF	20.00% 160V
C518	1-106-375-12	MYLAR 0.022UF	10.00% 250V	C631	1-126-942-61	ELECT 1000UF	20.00% 25V
C519	1-163-275-11	CERAMIC CHIP 0.001UF	5.00% 50V	C632	1-126-964-11	ELECT 10UF	20.00% 50V
C520	1-163-038-91	CERAMIC CHIP 0.1UF	25V	C633	1-163-009-91	CERAMIC CHIP 0.001UF	10.00% 50V
C524	1-163-037-11	CERAMIC CHIP 0.022UF	10.00% 50V	C634	1-128-562-11	ELECT 47UF	20.00% 100V
C525	1-123-024-21	ELECT 33UF	160V	C635	1-136-165-00	FILM 0.1UF	5.00% 50V
C531	1-126-964-11	ELECT 10UF	20.00% 50V	C636	1-136-479-11	FILM 0.001UF	2.00% 50V
C532	1-163-037-11	CERAMIC CHIP 0.022UF	10.00% 50V	C637	1-126-967-11	ELECT 47UF	20.00% 50V
C537	1-102-002-00	CERAMIC 680PF	10.00% 500V	C638	1-107-679-91	ELECT 10UF	20.00% 450V
C538	1-165-319-11	CERAMIC CHIP 0.1UF	50V	C639	1-104-665-11	ELECT 100UF	20.00% 25V
C540	1-136-206-11	MYLAR 0.033UF	10.00% 400V	C640	1-126-947-11	ELECT 47UF	20.00% 25V
C541	1-106-383-00	MYLAR 0.047UF	10.00% 200V	C641	1-115-785-11	ELECT 470UF	20.00% 16V
C543	1-162-134-11	CERAMIC 470PF	10.00% 2KV	C642	1-104-665-11	ELECT 100UF	20.00% 25V
C545	1-164-004-11	CERAMIC CHIP 0.1UF	10.00% 25V	C643	1-165-127-11	CERAMIC 470PF	10.00% 500V
C546	1-130-895-51	FILM 0.056UF	5.00% 400V	C645	1-164-004-11	CERAMIC CHIP 0.1UF	10.00% 25V
C548	1-162-134-11	CERAMIC 470PF	10.00% 2KV	C648	1-125-782-91	CERAMIC 4700PF	10.00% 1KV

REF.NO.	PART.NO	DESCRIPTION	REMARK	REF.NO.	PART.NO	DESCRIPTION	REMARK
C649	1-163-038-91	CERAMIC CHIP 0.1UF	25V	D003	8-719-109-69	DIODE RD3.6ES-B2	
C657	1-126-952-11	ELECT 1000UF	20.00% 35V	D005	8-719-929-15	DIODE HZS9.1NB2	
C1201	1-216-952-91	ELECT 1000UF	20.00% 35V	D006	8-719-109-89	DIODE RD5.6ESB2	
C1202	1-126-959-11	ELECT 0.47UF	20.00% 50V	D007	8-719-069-55	DIODE UZDZSTE-175.6B	
C1203	1-535-143-61	LEAD,JUMPER (5.00MM)		D008	8-719-074-43	DIODE BAS316-115	
C1207	1-126-960-11	ELECT 1UF	20.00% 50V	D010	8-719-074-43	DIODE BAS316-115	
C1208	1-126-953-11	ELECT 2200UF	20.00% 35V	D011	8-719-074-43	DIODE BAS316-115	
C1209	1-163-033-91	CERAMIC CHIP 0.022UF	50V	D012	8-719-929-15	DIODE HZS9.1NB2	
C1210	1-126-960-11	ELECT 1UF	20.00% 50V	D013	8-719-109-69	DIODE RD3.6ES-B2	
C1211	1-163-033-91	CERAMIC CHIP 0.022UF	50V	D014	1-216-295-91	SHORT 0	
C1213	1-164-346-11	CERAMIC CHIP 1UF	16V	D016	8-719-109-89	DIODE RD5.6ESB2	
C1215	1-126-952-11	ELECT 1000UF	20.00% 35V	D018	8-719-109-69	DIODE RD3.6ES-B2	
C1218	1-109-982-11	CERAMIC CHIP 1UF	10.00% 10V	D019	8-719-978-33	DIODE DTZ-TT11-6.8B	
C1219	1-104-666-11	ELECT 220UF	20.00% 25V	D021	8-719-978-33	DIODE DTZ-TT11-6.8B	
C1221	1-115-339-11	CERAMIC CHIP 0.1UF	10.00% 50V	D022	8-719-069-55	DIODE UZDZSTE-175.6B	
C1228	1-126-952-11	ELECT 1000UF	20.00% 35V	D035	8-719-069-55	DIODE UZDZSTE-175.6B	
C1229	1-163-001-11	CERAMIC CHIP 220PF	10.00% 50V	D036	8-719-069-55	DIODE UZDZSTE-175.6B	
C1230	1-163-001-11	CERAMIC CHIP 220PF	10.00% 50V	D051	8-719-081-98	DIODE MM3Z6V8T1	
C1231	1-163-001-11	CERAMIC CHIP 220PF	10.00% 50V	D101	8-719-083-87	DIODE UZDS-TE17-33B	
C1232	1-115-339-11	CERAMIC CHIP 0.1UF	10.00% 50V	D103	8-719-081-98	DIODE MM3Z6V8T1	
C1235	1-126-960-11	ELECT 1UF	20.00% 50V	D104	8-719-069-55	DIODE UZDZSTE-175.6B	
C1236	1-126-960-11	ELECT 1UF	20.00% 50V	D105	8-719-069-55	DIODE UZDZSTE-175.6B	
< CONNECTOR >				D106	8-719-069-55	DIODE UZDZSTE-175.6B	
CN001	*1-564-508-11	PLUG, CONNECTOR 5P		D107	8-719-069-55	DIODE UZDZSTE-175.6B	
CN002	*1-770-723-11	CONNECTOR, BOARD TO BOARD 8P		D203	8-719-069-55	DIODE UZDZSTE-175.6B	
CN003	*1-564-510-11	PLUG, CONNECTOR 7P		D207	8-719-069-60	DIODE UZDZSTE-179.1B	
CN101	1-695-915-21	TAB (CONTACT)		D210	8-719-069-55	DIODE UZDZSTE-175.6B	
CN405	*1-564-510-11	PLUG, CONNECTOR 7P		D211	8-719-069-60	DIODE UZDZSTE-179.1B	
CN406	*1-564-512-11	PLUG, CONNECTOR 9P		D212	8-719-914-43	DIODE DAN202K	
CN501	1-580-798-11	CONNECTOR PIN (DY)		D228	8-719-069-55	DIODE UZDZSTE-175.6B	
CN503	*1-564-506-11	PLUG, CONNECTOR 3P		D235	8-719-069-55	DIODE UZDZSTE-175.6B	
CN506	1-695-915-21	TAB (CONTACT)		D236	8-719-069-60	DIODE UZDZSTE-179.1B	
CN508	*1-564-508-11	PLUG, CONNECTOR 5P		D401	8-719-978-33	DIODE DTZ-TT11-6.8B	
CN509	1-695-915-11	TAB (CONTACT)		D402	8-719-081-98	DIODE MM3Z6V8T1	
CN510	1-691-771-11	PLUG (MICRO CONNECTOR) 9P		D403	8-719-978-33	DIODE DTZ-TT11-6.8B	
CN512	*1-770-723-11	CONNECTOR, BOARD TO BOARD 8P		D404	8-719-109-89	DIODE RD5.6ESB2	
CN601	1-580-843-11	PIN, CONNECTOR (POWER)		D405	8-719-081-98	DIODE MM3Z6V8T1	
CN602	1-508-765-00	PIN, CONNECTOR (5MM PITCH) 3P		D406	8-719-081-98	DIODE MM3Z6V8T1	
CN603	*1-508-786-00	PIN, CONNECTOR (5MM PITCH) 2P		D407	8-719-081-98	DIODE MM3Z6V8T1	
CN605	*1-691-960-11	PIN, CONNECTOR (PC BOARD) 3P		D408	8-719-978-33	DIODE DTZ-TT11-6.8B	
CN606	*1-695-292-11	PIN, CONNECTOR (POWER)		D410	8-719-978-33	DIODE DTZ-TT11-6.8B	
CN1200	*1-564-509-11	PLUG, CONNECTOR 6P		D411	8-719-978-33	DIODE DTZ-TT11-6.8B	
CN1201	*1-564-507-11	PLUG, CONNECTOR 4P		D412	8-719-081-98	DIODE MM3Z6V8T1	
CN1202	*1-564-506-11	PLUG, CONNECTOR 3P		D413	8-719-978-33	DIODE DTZ-TT11-6.8B	
< DIODE >				D414	8-719-081-98	DIODE MM3Z6V8T1	
D001	8-719-069-55	DIODE UZDZSTE-175.6B		D418	8-719-069-60	DIODE UZDZSTE-179.1B	
D002	8-719-069-55	DIODE UZDZSTE-175.6B		D419	8-719-084-66	DIODE BAT85 SB00018/D8	
				D420	8-719-081-98	DIODE MM3Z6V8T1	
				D421	8-719-084-66	DIODE BAT85 SB00018/D8	
				D422	8-719-978-33	DIODE DTZ-TT11-6.8B	

REF.NO.	PART.NO	DESCRIPTION	REMARK	REF.NO.	PART.NO	DESCRIPTION	REMARK
D423	8-719-081-98	DIODE MM3Z6V8T1				< FERRITE BEAD >	
D424	8-719-069-60	DIODE UDZSTE-179.1B					
D427	8-719-082-01	DIODE MM3Z12VT1		FB601	1-410-397-21	FERRITE	1.1UH
D428	8-719-978-33	DIODE DTZ-TT11-6.8B		FB602	1-410-397-21	FERRITE	1.1UH
D429	8-719-978-33	DIODE DTZ-TT11-6.8B		FB603	1-412-911-11	FERRITE	0UH
				FB604	1-410-397-21	FERRITE	1.1UH
D435	8-719-069-60	DIODE UDZSTE-179.1B		FB605	1-410-397-21	FERRITE	1.1UH
D436	8-719-069-60	DIODE UDZSTE-179.1B					
D501	8-719-979-85	DIODE EGP20G		FB606	1-412-911-11	FERRITE	0UH
D502	8-719-081-90	DIODE PDZ22B-115		FB607	1-412-911-11	FERRITE	0UH
D503	8-719-069-55	DIODE UDZSTE-175.6B					
						< FILTER >	
D504	8-719-074-43	DIODE BAS316-115		FL201	1-239-803-11	FILTER, EMI	
D512	8-719-302-43	DIODE EL1Z					
D513	8-719-979-85	DIODE EGP20G				< IC >	
D514	8-719-979-85	DIODE EGP20G		IC001	6-800-687-01	IC TDA9394H/N1/5/0423	
D534	8-719-302-43	DIODE EL1Z		IC004	8-759-575-72	IC M24C08-WMN6T	
				IC201	6-700-411-01	IC MSP3411G-PP-B8	
D535	8-719-908-03	DIODE GP08D		IC401	8-759-665-11	IC LM393DT	
D536	8-719-945-80	DIODE ERC06-15S		IC501	8-759-192-71	IC STV9379	
D537	8-719-070-62	DIODE PDZ9.1B-115					
D538	8-719-908-03	DIODE GP08D		IC531	8-759-665-11	IC LM393DT	
D539	8-719-312-10	DIODE RU4AM-T3		IC601	8-759-670-30	IC MCZ3001D	
				IC602	8-749-016-19	IC SE135N-LF4	
D541	1-216-295-91	SHORT 0		IC604	8-759-668-87	IC BA41W12ST-V5	
D573	8-719-082-00	DIODE MM3Z4V7T1		IC608	8-759-591-02	IC L78L33ABZ-AP	
D601	8-719-510-53	DIODE D4SB60L					
D602	8-719-911-19	DIODE 1SS119-25		IC609	8-759-468-89	IC TOP209P	
D604	8-719-083-94	DIODE FUF4005		IC1201	8-759-831-57	IC TDA7495S	
						< JACK >	
D608	8-719-063-70	DIODE D1NL20U		J401	1-766-296-21	CONNECTOR, DUAL SCART	
D610	8-719-110-41	DIODE RD15ES-B2		J404	1-784-632-11	JACK, PIN 2P	
D611	8-719-991-33	DIODE 1SS133T-77					
D612	8-719-991-33	DIODE 1SS133T-77				< COIL >	
D613	8-719-911-19	DIODE 1SS119-25		L001	1-408-611-31	INDUCTOR	47UH
				L002	1-414-187-11	INDUCTOR	47UH
D614	8-719-077-76	DIODE D2SB60A-F04		L004	1-408-611-31	INDUCTOR	47UH
D615	8-719-929-15	DIODE HZS9.1NB2		L006	1-408-611-31	INDUCTOR	47UH
D618	8-719-022-97	DIODE D2S4MF		L027	1-216-295-91	SHORT	0
D619	8-719-022-97	DIODE D2S4MF					
D620	8-719-109-85	DIODE RD5.1ESB2		L101	1-412-534-31	INDUCTOR	56UH
				L102	1-408-611-31	INDUCTOR	47UH
D621	8-719-109-89	DIODE RD5.6ESB2		L103	1-412-002-31	INDUCTOR	4.7UH
D623	8-719-911-19	DIODE 1SS119-25		L104	1-412-002-31	INDUCTOR	4.7UH
D624	8-719-052-90	DIODE D1NL40-TA2		L201	1-408-602-31	INDUCTOR	8.2UH
D625	8-719-062-39	DIODE D4SBL20UF1					
D627	8-719-063-71	DIODE D1NL20U-TA		L202	1-408-591-11	INDUCTOR	1UH
				L203	1-408-602-31	INDUCTOR	8.2UH
D628	8-719-083-49	DIODE P6KE200ASY		L205	1-408-591-11	INDUCTOR	1UH
D629	8-719-083-94	DIODE FUF4005		L206	1-535-143-61	LEAD, JUMPER	(5.0MM)
D631	8-719-921-63	DIODE MTZJ-7.5B		L207	1-408-591-11	INDUCTOR	1UH
D632	8-719-063-70	DIODE D1NL20U					
D633	8-719-109-69	DIODE RD3.6ES-B2		L401	1-410-993-42	INDUCTOR	1UH
				L403	1-410-993-42	INDUCTOR	1UH
D638	8-719-083-92	DIODE YG802C09RF122					
D640	8-719-921-63	DIODE MTZJ-7.5B					
D1203	8-719-914-43	DIODE DAN202K					
D1204	8-719-069-55	DIODE UDZSTE-175.6B					
D1230	8-719-074-43	DIODE BAS316-115					

Note : The components identified by shading and marked Δ are critical for safety. Replace only with the part numbers specified in the parts list.

A

REF.NO.	PART.NO	DESCRIPTION	REMARK	REF.NO.	PART.NO	DESCRIPTION	REMARK
L404	1-410-993-42	INDUCTOR	1UH	Q607	8-729-053-36	TRANSISTOR 2SK2640-01MR	
L405	1-535-143-61	LEAD, JUMPER	(5.0MM)	Q608	8-729-120-28	TRANSISTOR 2SC1623-L5L6	
L406	1-414-177-11	INDUCTOR	1UH	Q609	8-729-026-49	TRANSISTOR 2SA1037AK-T146	
L410	1-216-025-11	RES-CHIP	100 5% 1/10W	Q1230	8-729-027-56	TRANSISTOR DTC143TKA-T146	
L430	1-412-002-31	INDUCTOR	4.7UH	Q1231	8-729-027-56	TRANSISTOR DTC143TKA-T146	
L446	1-216-295-91	SHORT	0	Q1232	8-729-026-49	TRANSISTOR 2SA1037AK-T146	
L448	1-216-295-91	SHORT	0	Q1233	8-729-026-49	TRANSISTOR 2SA1037AK-T146	
L501	1-414-187-11	INDUCTOR	47UH	< RESISTOR >			
L502	1-412-529-11	INDUCTOR	22UH	JR3	1-216-296-11	SHORT	0
L503	1-412-521-31	INDUCTOR	4.7UH	JR4	1-216-295-91	SHORT	0
L504	1-535-143-61	LEAD, JUMPER	(5.0MM)	JR5	1-216-295-91	SHORT	0
L505	1-412-542-41	INDUCTOR	270UH	JR5	1-216-295-91	SHORT	0
L507	1-412-533-21	INDUCTOR	47UH	JR7	1-216-295-91	SHORT	0
L532	1-412-553-41	INDUCTOR	3.3MMH	JR9	1-216-295-91	SHORT	0
L533	1-406-989-21	INDUCTOR	10MH	JR10	1-216-295-91	SHORT	0
L534	1-216-025-11	RES-CHIP	100 5% 1/10W	JR16	1-216-296-11	SHORT	0
L535	1-459-111-00	INDUCTOR	10MH	JR17	1-216-295-91	SHORT	0
L601	1-408-603-31	INDUCTOR	10UH	JR21	1-216-818-11	RES-CHIP	560 5% 1/16W
L602	1-408-611-31	INDUCTOR	47UH	JR24	1-216-295-91	SHORT	0
L603	1-412-523-41	INDUCTOR	6.8UH	JR25	1-216-295-91	SHORT	0
L1201	1-535-143-61	LEAD, JUMPER	(5.0MM)	JR26	1-216-295-91	SHORT	0
L1203	1-535-143-61	LEAD, JUMPER	(5.0MM)	JR105	1-216-295-91	SHORT	0
< PHOTO COUPLER >				JR204	1-216-296-11	SHORT	0
PH601	Δ 8-749-016-21	IC TCET1103G		JR206	1-216-295-91	SHORT	0
< IC LINK >				JR208	1-216-295-91	SHORT	0
PS1201	1-533-597-31	LINK, IC	5A	JR209	1-216-295-91	SHORT	0
< TRANSISTOR >				JR210	1-216-295-91	SHORT	0
Q002	8-729-900-53	TRANSISTOR DTC114EK		JR211	1-216-296-11	SHORT	0
Q013	8-729-120-28	TRANSISTOR 2SC1623-L5L6		JR213	1-216-295-91	SHORT	0
Q014	8-729-120-28	TRANSISTOR 2SC1623-L5L6		JR401	1-216-295-91	SHORT	0
Q049	8-729-120-28	TRANSISTOR 2SC1623-L5L6		JR418	1-216-296-11	SHORT	0
Q202	8-729-120-28	TRANSISTOR 2SC1623-L5L6		JR423	1-216-296-11	SHORT	0
Q203	8-729-120-28	TRANSISTOR 2SC1623-L5L6		JR505	1-216-295-91	SHORT	0
Q212	8-729-422-33	TRANSISTOR 2SD601A-Q-TX		JR506	1-216-296-11	SHORT	0
Q401	8-729-026-49	TRANSISTOR 2SA1037AK-T146		JR601	1-216-295-91	SHORT	0
Q409	8-729-120-28	TRANSISTOR 2SC1623-L5L6		JR609	1-216-295-91	SHORT	0
Q411	8-729-120-28	TRANSISTOR 2SC1623-L5L6		JR610	1-216-295-91	SHORT	0
Q532	8-729-053-33	TRANSISTOR IRF614-037		JR1209	1-216-295-91	SHORT	0
Q533	8-729-049-08	TRANSISTOR BU2515DX-127		R001	1-216-295-91	SHORT	0
Q535	8-729-053-33	TRANSISTOR IRF614-037		R003	1-216-065-91	RES-CHIP	4.7K 5% 1/10W
Q576	8-729-422-33	TRANSISTOR 2SD601A-Q-TX		R004	1-216-033-00	RES-CHIP	220 5% 1/10W
Q601	8-729-026-49	TRANSISTOR 2SA1037AK-T146		R005	1-216-041-00	RES-CHIP	470 5% 1/10W
Q602	8-729-119-78	TRANSISTOR 2SC2785-HFE		R006	1-216-025-11	RES-CHIP	100 5% 1/10W
Q603	8-729-037-17	TRANSISTOR KRA104M-AT		R007	1-216-025-11	RES-CHIP	100 5% 1/10W
Q604	8-729-036-60	TRANSISTOR KRC104M-AT		R008	1-216-025-11	RES-CHIP	100 5% 1/10W
Q606	8-729-053-36	TRANSISTOR 2SK2640-01MR		R009	1-216-049-11	RES-CHIP	1K 5% 1/10W
				R010	1-216-049-11	RES-CHIP	1K 5% 1/10W
				R011	1-216-295-91	SHORT	0

REF.NO.	PART.NO	DESCRIPTION	REMARK	REF.NO.	PART.NO	DESCRIPTION	REMARK
R012	1-216-121-91	RES-CHIP	1M 5% 1/10W	R103	1-216-061-91	RES-CHIP	3.3K 5% 1/10W
R014	1-216-069-00	RES-CHIP	6.8K 5% 1/10W	R104	1-216-295-91	SHORT	0
R015	1-216-198-91	RES-CHIP	1K 5% 1/8W	R105	1-414-813-11	FERRITE	0UH
R017	1-216-025-11	RES-CHIP	100 5% 1/10W	R106	1-215-900-11	METAL OXIDE	22K 5% 2W
R018	1-208-820-11	METAL CHIP	39K 0.5% 1/10W	R107	1-216-025-11	RES-CHIP	100 5% 1/10W
R020	1-216-077-91	RES-CHIP	15K 5% 1/10W	R108	1-216-025-11	RES-CHIP	100 5% 1/10W
R023	1-216-035-00	RES-CHIP	270 5% 1/10W	R201	1-216-025-11	RES-CHIP	100 5% 1/10W
R024	1-216-025-11	RES-CHIP	100 5% 1/10W	R202	1-216-073-91	RES-CHIP	10K 5% 1/10W
R025	1-216-025-11	RES-CHIP	100 5% 1/10W	R203	1-216-025-11	RES-CHIP	100 5% 1/10W
R026	1-216-025-11	RES-CHIP	100 5% 1/10W	R211	1-216-081-00	RES-CHIP	22K 5% 1/10W
R027	1-216-025-11	RES-CHIP	100 5% 1/10W	R212	1-216-069-00	RES-CHIP	6.8K 5% 1/10W
R028	1-216-025-11	RES-CHIP	100 5% 1/10W	R213	1-216-081-00	RES-CHIP	22K 5% 1/10W
R029	1-216-061-91	RES-CHIP	3.3K 5% 1/10W	R214	1-216-041-00	RES-CHIP	470 5% 1/10W
R030	1-216-821-11	RES-CHIP	1K 5% 1/16W	R215	1-216-037-00	RES-CHIP	330 5% 1/10W
R031	1-216-061-91	RES-CHIP	3.3K 5% 1/10W	R216	1-216-097-11	RES-CHIP	100K 5% 1/10W
R032	1-216-061-91	RES-CHIP	3.3K 5% 1/10W	R217	1-216-222-00	RES-CHIP	10K 5% 1/8W
R033	1-216-073-91	RES-CHIP	10K 5% 1/10W	R220	1-216-031-00	RES-CHIP	180 5% 1/10W
R034	1-216-129-00	RES-CHIP	2.2M 5% 1/10W	R221	1-216-190-00	RES-CHIP	470 5% 1/8W
R035	1-216-101-00	RES-CHIP	150K 5% 1/10W	R232	1-216-025-11	RES-CHIP	100 5% 1/10W
R036	1-216-083-00	RES-CHIP	27K 5% 1/10W	R233	1-216-069-00	RES-CHIP	6.8K 5% 1/10W
R039	1-216-065-91	RES-CHIP	4.7K 5% 1/10W	R234	1-216-069-00	RES-CHIP	6.8K 5% 1/10W
R040	1-216-033-00	RES-CHIP	220 5% 1/10W	R235	1-216-057-00	RES-CHIP	2.2K 5% 1/10W
R041	1-216-025-11	RES-CHIP	100 5% 1/10W	R236	1-216-057-00	RES-CHIP	2.2K 5% 1/10W
R042	1-216-025-11	RES-CHIP	100 5% 1/10W	R238	1-216-025-11	RES-CHIP	100 5% 1/10W
R044	1-216-073-91	RES-CHIP	10K 5% 1/10W	R246	1-260-107-11	CARBON	4.7K 5% 1/2W
R045	1-216-129-00	RES-CHIP	2.2M 5% 1/10W	R248	1-249-429-11	CARBON	10K 5% 1/4W
R046	1-216-025-11	RES-CHIP	100 5% 1/10W	R249	1-216-097-11	RES-CHIP	100K 5% 1/10W
R047	1-216-025-11	RES-CHIP	100 5% 1/10W	R250	1-216-230-00	RES-CHIP	22K 5% 1/8W
R048	1-216-073-91	RES-CHIP	10K 5% 1/10W	R251	1-216-069-00	RES-CHIP	6.8K 5% 1/10W
R049	1-216-049-11	RES-CHIP	1K 5% 1/10W	R252	1-216-069-00	RES-CHIP	6.8K 5% 1/10W
R050	1-216-025-11	RES-CHIP	100 5% 1/10W	R253	1-216-025-11	RES-CHIP	100 5% 1/10W
R051	1-216-295-91	SHORT	0	R254	1-216-025-11	RES-CHIP	100 5% 1/10W
R052	1-216-295-91	SHORT	0	R401	1-410-993-42	INDUCTOR	1UH
R055	1-216-025-11	RES-CHIP	100 5% 1/10W	R402	1-216-041-00	RES-CHIP	470 5% 1/10W
R056	1-216-081-00	RES-CHIP	22K 5% 1/10W	R403	1-216-113-00	RES-CHIP	470K 5% 1/10W
R060	1-216-025-11	RES-CHIP	100 5% 1/10W	R404	1-216-113-00	RES-CHIP	470K 5% 1/10W
R061	1-216-025-11	RES-CHIP	100 5% 1/10W	R405	1-216-829-11	RES-CHIP	4.7K 5% 1/16W
R070	1-216-025-11	RES-CHIP	100 5% 1/10W	R406	1-216-296-11	SHORT	0
R071	1-216-049-11	RES-CHIP	1K 5% 1/10W	R407	1-216-022-00	RES-CHIP	75 5% 1/10W
R072	1-127-715-91	CERAMIC CHIP	0.22 10% 16V	R408	1-216-022-00	RES-CHIP	75 5% 1/10W
R073	1-216-057-00	RES-CHIP	2.2K 5% 1/10W	R409	1-216-025-11	RES-CHIP	100 5% 1/10W
R074	1-216-073-91	RES-CHIP	10K 5% 1/10W	R410	1-216-025-11	RES-CHIP	100 5% 1/10W
R090	1-216-057-00	RES-CHIP	2.2K 5% 1/10W	R411	1-216-022-00	RES-CHIP	75 5% 1/10W
R091	1-216-081-00	RES-CHIP	22K 5% 1/10W	R412	1-216-025-11	RES-CHIP	100 5% 1/10W
R092	1-216-073-91	RES-CHIP	10K 5% 1/10W	R413	1-216-113-00	RES-CHIP	470K 5% 1/10W
R094	1-216-025-11	RES-CHIP	100 5% 1/10W	R414	1-216-022-00	RES-CHIP	75 5% 1/10W
R095	1-216-065-91	RES-CHIP	4.7K 5% 1/10W	R415	1-216-022-00	RES-CHIP	75 5% 1/10W
R096	1-216-073-91	RES-CHIP	10K 5% 1/10W	R416	1-216-027-00	RES-CHIP	120 5% 1/10W
R101	1-216-093-91	RES-CHIP	68K 5% 1/10W	R417	1-216-113-00	RES-CHIP	470K 5% 1/10W
R102	1-216-097-11	RES-CHIP	100K 5% 1/10W	R418	1-216-113-00	RES-CHIP	470K 5% 1/10W

Note : The components identified by shading and marked Δ are critical for safety. Replace only with the part numbers specified in the parts list.

A

REF.NO.	PART.NO	DESCRIPTION	REMARK	REF.NO.	PART.NO	DESCRIPTION	REMARK
R419	1-216-022-00	RES-CHIP 75 5%	1/10W	R523	1-216-121-11	RES-CHIP 1M 5%	1/10W
R420	1-216-073-91	RES-CHIP 10K 5%	1/10W	R524	1-216-075-00	RES-CHIP 12K 5%	1/10W
R421	1-216-049-11	RES-CHIP 1K 5%	1/10W	R525	1-216-057-00	RES-CHIP 2.2K 5%	1/10W
R422	1-216-829-11	RES-CHIP 4.7K 5%	1/16W	R526	1-216-089-91	RES-CHIP 47K 5%	1/10W
R423	1-216-113-00	RES-CHIP 470K 5%	1/10W	R527	1-216-077-91	RES-CHIP 15K 5%	1/10W
R424	1-216-113-00	RES-CHIP 470K 5%	1/10W	R528	1-216-097-11	RES-CHIP 100K 5%	1/10W
R425	1-216-085-91	RES-CHIP 33K 5%	1/10W	R529	1-216-073-91	RES-CHIP 10K 5%	1/10W
R426	1-216-073-91	RES-CHIP 10K 5%	1/10W	R530	1-216-085-91	RES-CHIP 33K 5%	1/10W
R427	1-216-113-00	RES-CHIP 470K 5%	1/10W	R531	1-216-057-00	RES-CHIP 2.2K 5%	1/10W
R428	1-216-073-91	RES-CHIP 10K 5%	1/10W	R532	1-216-065-91	RES-CHIP 4.7K 5%	1/10W
R429	1-216-089-91	RES-CHIP 47K 5%	1/10W	R533	1-216-077-91	RES-CHIP 15K 5%	1/10W
R430	1-216-073-91	RES-CHIP 10K 5%	1/10W	R538	1-535-143-71	LEAD, JUMPER (7.5MM)	
R431	1-216-073-91	RES-CHIP 10K 5%	1/10W	R539	1-535-143-41	LEAD, JUMPER (17.5MM)	
R433	1-216-073-91	RES-CHIP 10K 5%	1/10W	R543	1-216-065-91	RES-CHIP 4.7K 5%	1/10W
R434	1-216-073-91	RES-CHIP 10K 5%	1/10W	R544	1-216-065-91	RES-CHIP 4.7K 5%	1/10W
R435	1-216-295-91	SHORT 0		R547	1-535-143-71	LEAD, JUMPER (7.5MM)	
R438	1-216-022-00	RES-CHIP 75 5%	1/10W	R548	1-249-387-11	CARBON 3.3 5%	1/4W
R440	1-216-049-11	RES-CHIP 1K 5%	1/10W	R549	1-535-143-71	LEAD, JUMPER (7.5MM)	
R441	1-216-051-00	RES-CHIP 1.2K 5%	1/10W	R551	1-215-873-00	METAL OXIDE 4.7K 5%	1W
R442	1-216-085-91	RES-CHIP 33K 5%	1/10W	R552	1-216-848-91	RES-CHIP 180K 5%	1/16W
R443	1-216-073-91	RES-CHIP 10K 5%	1/10W	R553	1-249-381-11	CARBON 1 5%	1/4W
R444	1-216-061-91	RES-CHIP 3.3K 5%	1/10W	R555	1-216-059-00	RES-CHIP 2.7K 5%	1/10W
R445	1-216-022-00	RES-CHIP 75 5%	1/10W	R556	1-215-916-00	METAL OXIDE 680 5%	3W
R446	1-216-113-00	RES-CHIP 470K 5%	1/10W	R557	1-216-067-00	RES-CHIP 5.6K 5%	1/10W
R447	1-216-295-91	SHORT 0		R558	1-216-057-00	RES-CHIP 2.2K 5%	1/10W
R448	1-216-113-00	RES-CHIP 470K 5%	1/10W	R589	1-216-097-11	RES-CHIP 100K 5%	1/10W
R449	1-216-295-91	SHORT 0		R590	1-216-081-91	RES-CHIP 22K 5%	1/10W
R450	1-216-041-00	RES-CHIP 470 5%	1/10W	R591	1-215-892-11	METAL OXIDE 1K 5%	2W
R451	1-216-041-00	RES-CHIP 470 5%	1/10W	R595	1-249-377-91	CARBON 0.47 5%	1/4W
R453	1-216-171-00	RES-CHIP 75 5%	1/8W	R602	1-202-968-11	CEMENTED 1.2 5%	10W
R454	1-216-001-00	RES-CHIP 10 5%	1/10W	R603	1-202-933-61	FUSIBLE 0.1 10%	1/2W
R460	1-216-049-11	RES-CHIP 1K 5%	1/10W	R605	1-216-049-11	RES-CHIP 1K 5%	1/10W
R461	1-216-022-00	RES-CHIP 75 5%	1/10W	R608	1-216-073-91	RES-CHIP 10K 5%	1/10W
R462	1-216-178-00	RES-CHIP 150 5%	1/8W	R609	1-216-677-11	METAL CHIP 12K 0.5%	1/10W
R500	1-216-061-91	RES-CHIP 3.3K 5%	1/10W	R610	1-215-481-00	METAL 330K 1%	1/4W
R501	1-216-091-00	RES-CHIP 56K 5%	1/10W	R611	1-216-059-00	RES-CHIP 2.7K 5%	1/10W
R502	1-216-073-91	RES-CHIP 10K 5%	1/10W	R612	1-249-429-11	CARBON 10K 5%	1/4W
R503	1-215-888-00	METAL OXIDE 220 5%	2W	R613	Δ 1-219-720-91	METAL 10M 5%	1W
R504	1-249-385-11	CARBON 2.2 5%	1/4W	R615	1-215-385-00	METAL 33 1%	1/4W
R505	1-216-671-11	METAL CHIP 6.8K 0.5%	1/10W	R618	1-247-889-00	CARBON 270K 5%	1/4W
R506	1-208-796-11	METAL CHIP 3.9K 0.5%	1/10W	R619	1-216-065-91	RES-CHIP 4.7K 5%	1/10W
R507	1-216-349-00	METAL OXIDE 1 5%	1W	R621	1-216-113-00	RES-CHIP 470K 5%	1/10W
R508	1-216-673-11	METAL CHIP 8.2K 0.5%	1/10W	R622	1-216-073-91	RES-CHIP 10K 5%	1/10W
R509	1-208-796-11	METAL CHIP 3.9K 0.5%	1/10W	R623	1-216-065-91	RES-CHIP 4.7K 5%	1/10W
R510	1-216-113-00	RES-CHIP 470K 5%	1/10W	R624	1-216-001-00	RES-CHIP 10 5%	1/10W
R512	1-249-382-11	CARBON 1.2 5%	1/4W	R625	1-216-073-91	RES-CHIP 10K 5%	1/10W
R514	1-249-377-11	CARBON 0.47 5%	1/4W	R627	1-249-389-11	CARBON 4.7 5%	1/4W
R515	1-249-377-11	CARBON 0.47 5%	1/4W	R628	1-247-791-91	CARBON 22 5%	1/4W
R520	1-215-884-11	METAL OXIDE 47 5%	2W	R629	1-216-073-91	RES-CHIP 10K 5%	1/10W
R522	1-216-097-11	RES-CHIP 100K 5%	1/10W	R631	1-216-101-00	RES-CHIP 150K 5%	1/10W

REF.NO.	PART.NO	DESCRIPTION	REMARK	REF.NO.	PART.NO	DESCRIPTION	REMARK
R632	1-249-417-11	CARBON	1K 5% 1/4W	T602	△ 1-431-732-31	TRANSFORMER, CONVERTER (SRT)	
R633	1-215-481-00	METAL	330K 1% 1/4W	T603	△ 1-435-976-11	TRANSFORMER, CONVERTER (PIT)	
R634	1-217-625-00	METAL	0.05 10% 2W			< THERMISTOR >	
R635	1-260-300-11	CARBON	4.7 5% 1/2W	TH601	1-803-586-41	THERMISTOR	
R636	1-249-413-11	CARBON	470 5% 1/4W	THP601	△ 1-803-951-11	THERMISTOR, PTC	
R637	1-216-041-00	RES-CHIP	470 5% 1/10W			< CRYSTAL >	
R639	1-208-814-91	METAL CHIP	22K 0.5% 1/10W	X001	1-578-774-71	VIBRATOR, CRYSTAL	
R640	1-208-830-11	METAL CHIP	100K 0.5% 1/10W	X201	1-760-628-11	VIBRATOR, CRYSTAL	
R641	1-216-097-11	RES-CHIP	100K 5% 1/10W			A Board Variant Parts KD-28DX40	
R642	1-249-405-11	CARBON	100 5% 1/4W			< CAPACITOR >	
R643	1-216-089-91	RES-CHIP	47K 5% 1/10W	C522	1-137-447-11	MYLAR 0.27UF 5.00% 50V	
R645	1-216-073-91	RES-CHIP	10K 5% 1/10W	C536	1-115-521-11	FILM 0.82UF 5.00% 250V	
R647	1-216-049-11	RES-CHIP	1K 5% 1/10W	C539	1-111-230-11	ELECT 1UF 20.00% 160V	
R648	1-215-481-00	METAL	330K 1% 1/4W	C542	1-162-115-00	CERAMIC 330PF 10.00% 2KV	
R649	1-208-805-11	METAL CHIP	9.1K 0.5% 1/10W	C547	1-115-521-11	FILM 0.82UF 5.00% 250V	
R650	1-208-758-11	METAL CHIP	100 0.5% 1/10W	C555	1-117-652-11	FILM 22000PF 3.00% 1.2KV	
R651	1-220-926-11	FUSIBLE	0.47 10% 1/2W			< RESISTOR >	
R652	1-216-081-00	RES-CHIP	22K 5% 1/10W	R022	1-216-089-91	RES-CHIP 47K 5% 1/10W	
R653	1-216-073-91	RES-CHIP	10K 5% 1/10W	R053	1-216-077-91	RES-CHIP 15K 5% 1/10W	
R654	1-216-001-00	RES-CHIP	10 5% 1/10W	R455	1-216-295-91	SHORT 0	
R656	1-216-365-00	METAL OXIDE	0.47 5% 2W	R513	1-216-105-91	RES-CHIP 220K 5% 1/10W	
R658	1-202-968-11	CEMENTED	1.2 5% 10W	R516	1-214-907-00	METAL 56K 1% 1/2W	
R660	1-247-807-31	CARBON	100 5% 1/4W	R517	1-215-451-00	METAL 18K 1% 1/4W	
R1202	1-216-073-91	RES-CHIP	10K 5% 1/10W	R518	1-216-059-00	RES-CHIP 2.7K 5% 1/10W	
R1203	1-216-049-11	RES-CHIP	1K 5% 1/10W	R521	1-216-105-91	RES-CHIP 220K 5% 1/10W	
R1207	1-216-077-91	RES-CHIP	15K 5% 1/10W	R534	1-216-097-11	RES-CHIP 100K 5% 1/10W	
R1210	1-216-077-91	RES-CHIP	15K 5% 1/10W	R535	1-216-099-00	RES-CHIP 120K 5% 1/10W	
R1213	1-216-049-11	RES-CHIP	1K 5% 1/10W	R540	1-212-970-00	FUSIBLE 33 5% 1/2W	
R1214	1-216-049-11	RES-CHIP	1K 5% 1/10W	R546	1-216-480-11	METAL OXIDE 820 5% 3W	
R1215	1-216-049-11	RES-CHIP	1K 5% 1/10W	R568	1-215-916-00	METAL OXIDE 680 5% 3W	
R1216	1-216-025-11	RES-CHIP	100 5% 1/10W	R583	1-216-073-91	RES-CHIP 10K 5% 1/10W	
R1217	1-216-341-11	METAL OXIDE	0.22 5% 1W	R600	1-216-641-11	METAL CHIP 390 0.5% 1/10W	
R1230	1-216-041-00	RES-CHIP	470 5% 1/10W	R601	1-216-643-11	METAL CHIP 470 0.5% 1/10W	
R1231	1-216-113-00	RES-CHIP	470K 5% 1/10W			< TRANSFORMER >	
R1232	1-216-041-00	RES-CHIP	470 5% 1/10W	T533	1-433-980-12	TRANSFORMER, HORIZONTAL LINEAR	
R1233	1-216-113-00	RES-CHIP	470K 5% 1/10W			A Board Variant Parts KD-32DX40	
R1235	1-216-073-91	RES-CHIP	10K 5% 1/10W			< CAPACITOR >	
R1236	1-216-073-91	RES-CHIP	10K 5% 1/10W	C536	1-115-522-11	FILM 1UF 5.00% 250V	
		< RELAY >		C539	1-107-667-11	ELECT 2.2UF 20.00% 160V	
RY601	△ 1-755-388-11	RELAY (AC POWER)		C542	1-161-754-00	CERAMIC 0.001UF 10.00% 2KV	
		< SWITCH >		C547	1-109-844-11	FILM 0.68UF 5.00% 250V	
SW532	1-572-707-11	SWITCH, LEVER					
		< TRANSFORMER >					
T511	△ 1-453-308-41	TRANSFORMER ASSY, FLYBACK (NX4521//Z2B4)					
T531	1-437-210-11	TRANSFORMER, HORIZONTAL DRIVE					
T532	1-426-981-91	TRANSFORMER, FERRITE (PMT)					

Note : The components identified by shading and marked Δ are critical for safety. Replace only with the part numbers specified in the parts list.

A **B** **F3**

REF.NO.	PART.NO	DESCRIPTION	REMARK	REF.NO.	PART.NO	DESCRIPTION	REMARK
C555	1-127-717-11	FILM	19000PF 3.00% 1.2KV	Q8307	8-729-120-28	TRANSISTOR 2SC1623-L5L6	
	< RESISTOR >				< RESISTOR >		
JR101	1-216-295-91	SHORT	0	R8301	1-216-809-11	RES-CHIP 100 5% 1/16W	
R022	1-216-689-11	RES-CHIP	39K 5% 1/10W	R8302	1-216-809-11	RES-CHIP 100 5% 1/16W	
R053	1-216-095-00	RES-CHIP	82K 5% 1/10W	R8303	1-216-809-11	RES-CHIP 100 5% 1/16W	
R455	1-412-002-31	INDUCTOR	4.7UH	R8304	1-216-817-11	RES-CHIP 470 5% 1/16W	
R516	1-214-905-11	METAL	47K 1% 1/2W	R8305	1-216-817-11	RES-CHIP 470 5% 1/16W	
R517	1-215-453-00	METAL	22K 1% 1/4W	R8306	1-216-817-11	RES-CHIP 470 5% 1/16W	
R518	1-216-069-00	RES-CHIP	6.8K 5% 1/10W	R8307	1-216-817-11	RES-CHIP 470 5% 1/16W	
R534	1-216-111-00	RES-CHIP	390K 5% 1/10W	R8308	1-216-817-11	RES-CHIP 470 5% 1/16W	
R535	1-216-105-91	RES-CHIP	220K 5% 1/10W	R8309	1-216-817-11	RES-CHIP 470 5% 1/16W	
R540	1-212-974-00	FUSIBLE	47 5% 1/2W	R8310	1-216-829-11	RES-CHIP 4.7K 5% 1/16W	
R546	1-215-917-11	METAL OXIDE	1K 5% 3W	R8311	1-216-835-11	RES-CHIP 15K 5% 1/16W	
R568	1-216-480-11	METAL OXIDE	820 5% 3W	R8312	1-216-833-11	RES-CHIP 10K 5% 1/16W	
R583	1-216-077-91	RES-CHIP	15K 5% 1/10W	R8313	1-216-835-11	RES-CHIP 15K 5% 1/16W	
R600	1-216-629-11	METAL CHIP	120 0.5% 1/10W	R8314	1-216-833-11	RES-CHIP 10K 5% 1/16W	
R601	1-216-647-11	METAL CHIP	680 0.5% 1/10W	R8315	1-216-835-11	RES-CHIP 15K 5% 1/16W	
	< TRANSFORMER >			R8316	1-216-833-11	RES-CHIP 10K 5% 1/16W	
T533	1-429-306-11	TRANSFORMER, HORIZONTAL LINEAR		R8317	1-216-821-11	RES-CHIP 1K 5% 1/16W	
				R8318	1-216-821-11	RES-CHIP 1K 5% 1/16W	
				R8319	1-216-821-11	RES-CHIP 1K 5% 1/16W	

***A-1620-146-A B Board, Complete**

	< CAPACITOR >		
C8301	1-126-947-11	ELECT	47UF 20.00% 25V
C8302	1-126-964-11	ELECT	10UF 20.00% 50V
C8303	1-126-964-11	ELECT	10UF 20.00% 50V
C8304	1-126-964-11	ELECT	10UF 20.00% 50V
C8305	1-107-826-11	CERAMIC CHIP	0.1UF 10.00% 16V
C8306	1-107-826-11	CERAMIC CHIP	0.1UF 10.00% 16V
C8307	1-107-826-11	CERAMIC CHIP	0.1UF 10.00% 16V
C8308	1-107-826-11	CERAMIC CHIP	0.1UF 10.00% 16V
	< CONNECTOR >		
CN8301	1-564-521-11	PLUG, CONNECTOR	6P
CN8302	*1-778-770-11	CONNECTOR, BOARD TO BOARD (PLUG)	
	< IC >		
IC8301	8-759-385-77	IC MC14053	BDR2
	< TRANSISTOR >		
Q8301	8-729-900-53	TRANSISTOR	DTC114EK
Q8302	8-729-120-28	TRANSISTOR	2SC1623-L5L6
Q8303	8-729-120-28	TRANSISTOR	2SC1623-L5L6
Q8304	8-729-120-28	TRANSISTOR	2SC1623-L5L6
Q8305	8-729-120-28	TRANSISTOR	2SC1623-L5L6
Q8306	8-729-120-28	TRANSISTOR	2SC1623-L5L6

***A-1624-109-A F3 Board, Complete**

	*4-374-846-01 COVER, CAPACITOR, CAP TYPE		
	< CAPACITOR >		
C3601	1-113-924-51	CERAMIC	0.0047UF 20.00% 250V
C3602	1-136-516-12	METAL	0.1UF 20.00% 300V
C3603	1-136-516-12	METAL	0.1UF 20.00% 300V
	< CONNECTOR >		
CN3601	1-580-843-11	PIN, CONNECTOR (POWER)	
CN3602	1-695-915-21	TAB (CONTACT)	
CN3603	1-580-843-11	PIN, CONNECTOR (POWER)	
	< FUSE >		
F3601	Δ 1-576-232-21	FUSE (H.B.C.)	5A/250V
	*1-533-725-11 HOLDER, FUSE (F3601)		
	< RESISTOR >		
R3601	1-202-719-91	SOLID	1M 10% 1/2W
	< TRANSFORMER >		
T3601	1-433-488-11	TRANSFORMER, LINE FILTER	
T3602	1-433-488-11	TRANSFORMER, LINE FILTER	

Note : The components identified by shading and marked Δ are critical for safety. Replace only with the part numbers specified in the parts list.

F3 **F6** **C** **D3**

REF.NO.	PART.NO	DESCRIPTION	REMARK	REF.NO.	PART.NO	DESCRIPTION	REMARK
		< VARISTOR >					
VD3601	1-803-830-11	VARISTOR (ERZ14D621)		D1802	8-719-110-17	DIODE RD10ESB2	
				D1803	8-719-110-17	DIODE RD10ESB2	
						< IC >	
				IC701	8-759-562-43	IC TDA6108JF/N1B	
				IC1801	8-759-603-37	IC M5216P	
						< SOCKET >	
				J701	Δ 1-251-732-11	SOCKET, CRT	
						< COIL >	
				L704	1-414-183-41	INDUCTOR 10UH	
						< RESISTOR >	
				R701	1-247-903-00	CARBON 1M 5% 1/4W	
				R702	1-249-429-11	CARBON 10K 5% 1/4W	
				R703	1-247-903-00	CARBON 1M 5% 1/4W	
				R704	1-535-143-21	LEAD, JUMPER (12.5MM)	
				R705	1-215-869-11	METAL OXIDE 1K 5% 1W	
				R706	1-249-411-11	CARBON 330 5% 1/4W	
				R712	1-215-869-11	METAL OXIDE 1K 5% 1W	
				R716	1-249-411-11	CARBON 330 5% 1/4W	
				R718	1-202-814-11	SOLID 33K 10% 1/2W	
				R726	1-215-869-11	METAL OXIDE 1K 5% 1W	
				R727	1-249-411-11	CARBON 330 5% 1/4W	
				R728	1-249-390-11	CARBON 5.6 5% 1/4W	
				R741	1-202-549-00	SOLID 100 20% 1/2W	
				R1801	1-249-441-11	CARBON 100K 5% 1/4W	
				R1805	1-249-429-11	CARBON 10K 5% 1/4W	
				R1806	1-247-899-11	CARBON 680K 5% 1/4W	
				R1807	1-249-429-11	CARBON 10K 5% 1/4W	
				R1808	1-249-429-11	CARBON 10K 5% 1/4W	
				R1809	1-249-429-11	CARBON 10K 5% 1/4W	
				R1810	1-249-429-11	CARBON 10K 5% 1/4W	
						< VARIABLE RESISTOR >	
				RV702	1-241-656-21	RES, ADJ, METAL FILM 110M	
						< CAPACITOR >	
				C2802	1-126-965-91	ELECT 22UF 20.00% 50V	
						< CONNECTOR >	
				CN2801	*1-564-506-11	PLUG, CONNECTOR 3P	
				CN2802	*1-785-270-12	PIN, DY CONNECTOR (PC BOARD)	
				CN2803	*1-580-798-11	CONNECTOR PIN (DY) 6P	
						< DIODE >	
				D701	8-719-991-33	DIODE 1SS133T-77	
				D702	8-719-901-83	DIODE 1SS83	
				D703	8-719-901-83	DIODE 1SS83	
				D705	8-719-302-43	DIODE EL1Z	
				D706	8-719-901-83	DIODE 1SS83	
				D707	8-719-901-83	DIODE 1SS83	
				D708	8-719-109-97	DIODE RD6.8ES-B2	
				D709	8-719-109-97	DIODE RD6.8ES-B2	
				D710	8-719-109-97	DIODE RD6.8ES-B2	
				D1801	8-719-110-17	DIODE RD10ESB2	
						< CONNECTOR >	
				CN702	1-695-915-11	TAB (CONTACT)	
				CN703	*1-564-510-11	PLUG, CONNECTOR 7P	
				CN706	1-695-915-11	TAB (CONTACT)	
				CN707	*1-564-508-11	PLUG, CONNECTOR 5P	
				CN1801	*1-564-506-11	PLUG, CONNECTOR 3P	
						< SWITCH >	
				S7601	Δ 1-571-433-21	SWITCH, PUSH (AC POWER)	
						< CAPACITOR >	
				C701	1-136-189-00	MYLAR 0.1UF 10.00% 250V	
				C702	1-126-964-11	ELECT 10UF 20.00% 50V	
				C703	1-101-004-00	CERAMIC 0.01UF 50V	
				C704	1-107-649-11	ELECT 2.2UF 20.00% 250V	
				C705	1-162-318-11	CERAMIC 0.001UF 10.00% 500V	
				C706	1-162-318-11	CERAMIC 0.001UF 10.00% 500V	
				C708	1-115-350-61	CERAMIC 0.0047UF 2KV	
				C710	1-107-652-11	ELECT 10UF 20.00% 250V	
				C1803	1-101-005-00	CERAMIC 0.022UF 50V	
				C1804	1-126-964-11	ELECT 10UF 20.00% 50V	
				C1805	1-101-880-00	CERAMIC 47PF 5.00% 50V	
						< CONNECTOR >	
				CN702	1-695-915-11	TAB (CONTACT)	
				CN703	*1-564-510-11	PLUG, CONNECTOR 7P	
				CN706	1-695-915-11	TAB (CONTACT)	
				CN707	*1-564-508-11	PLUG, CONNECTOR 5P	
				CN1801	*1-564-506-11	PLUG, CONNECTOR 3P	
						< DIODE >	
				D701	8-719-991-33	DIODE 1SS133T-77	
				D702	8-719-901-83	DIODE 1SS83	
				D703	8-719-901-83	DIODE 1SS83	
				D705	8-719-302-43	DIODE EL1Z	
				D706	8-719-901-83	DIODE 1SS83	
				D707	8-719-901-83	DIODE 1SS83	
				D708	8-719-109-97	DIODE RD6.8ES-B2	
				D709	8-719-109-97	DIODE RD6.8ES-B2	
				D710	8-719-109-97	DIODE RD6.8ES-B2	
				D1801	8-719-110-17	DIODE RD10ESB2	

REF.NO.	PART.NO	DESCRIPTION	REMARK	REF.NO.	PART.NO	DESCRIPTION	REMARK
	< DIODE >				< RESISTOR >		
D2801	8-719-991-33	DIODE 1S133T-77		JR8801	1-216-864-11	SHORT 0	
	< TRANSISTOR >				< CAPACITOR >		
Q2801	8-729-119-78	TRANSISTOR 2SC2785-HFE		R8803	1-249-441-11	CARBON 100K 5% 1/4W	
Q2802	8-729-119-78	TRANSISTOR 2SC2785-HFE		R8804	1-216-825-11	RES-CHIP 2.2K 5% 1/16W	
	< RESISTOR >			R8805	1-216-833-11	RES-CHIP 10K 5% 1/16W	
R2801	1-249-421-11	CARBON 2.2K 5% 1/4W		R8806	1-216-809-11	RES-CHIP 100 5% 1/16W	
R2802	1-249-421-11	CARBON 2.2K 5% 1/4W		R8812	1-218-879-11	METAL CHIP 22K 0.5% 1/16W	
	< RELAY >			*A-1645-050-A VM Board, Complete (KD-28DX40)			
RY2801	1-755-172-11	RELAY		*A-1645-049-A VM Board, Complete (KD-32DX40)			
	< TRANSFORMER >			VM Board Common Parts			
T2801	1-419-090-11	COIL, CHOKE (100UH)		4-352-844-01 PIN, LEAD, COATING			
*A-1642-281-A D2 Board, Complete					< CAPACITOR >		
	< CAPACITOR >			C1701	1-104-665-11	ELECT 100UF 20.00% 25V	
C8802	1-136-104-00	FILM 0.16UF 5.00% 200V		C1702	1-162-970-11	CERAMIC CHIP 0.01UF 10.00% 25V	
C8803	1-117-670-11	FILM 0.82UF 5.00% 250V		C1703	1-162-955-91	CERAMIC CHIP 150PF 5.00% 50V	
C8804	1-136-207-11	MYLAR 0.047UF 10.00% 250V		C1704	1-104-665-11	ELECT 100UF 20.00% 25V	
	< CONNECTOR >			C1705	1-162-919-11	CERAMIC CHIP 22PF 5.00% 50V	
CN8801	*1-778-770-11	CONNECTOR, BOARD TO BOARD (PLUG)		C1710	1-106-375-12	MYLAR 0.022UF 10.00% 250V	
CN8802	*1-564-506-11	PLUG, CONNECTOR 3P		C1711	1-106-375-12	MYLAR 0.022UF 10.00% 250V	
	< DIODE >			C1713	1-106-375-12	MYLAR 0.022UF 10.00% 250V	
D8801	8-719-923-60	DIODE MTZJ-T-77-9.1A		C1721	1-107-655-11	ELECT 47UF 20.00% 250V	
D8802	8-719-302-43	DIODE EL1Z		C1722	1-136-153-00	FILM 0.01UF 5.00% 50V	
D8803	8-719-010-34	DIODE MTZJ-4.7B		C1723	1-126-935-11	ELECT 470UF 20.00% 10V	
	< IC >			C1728	1-126-935-11	ELECT 470UF 20.00% 10V	
IC8801	8-749-010-64	PHOTO COUPLER PC123F2		C1732	1-162-970-11	CERAMIC CHIP 0.01UF 10.00% 25V	
	< COIL >			C1733	1-126-947-11	ELECT 47UF 20.00% 25V	
L8802	1-406-978-11	INDUCTOR 150UH		C1734	1-126-947-11	ELECT 47UF 20.00% 25V	
	< TRANSISTOR >			C1737	1-104-999-11	MYLAR 0.1UF 5.00% 200V	
Q8801	8-729-034-09	TRANSISTOR 2SK2518-01MR		C1844	1-129-716-00	FILM 0.015UF 5.00% 630V	
Q8802	1-801-806-11	TRANSISTOR DTC144EKA		C1845	1-129-725-00	FILM 0.082UF 5.00% 400V	
Q8803	1-801-806-11	TRANSISTOR DTC144EKA		C1901	1-162-927-11	CERAMIC CHIP 100PF 5.00% 50V	
				C1902	1-137-374-11	MYLAR 0.047UF 5.00% 50V	
				C1903	1-126-964-11	ELECT 10UF 20.00% 50V	
				C1904	1-137-366-11	MYLAR 0.0022UF 5.00% 50V	
				C1905	1-137-374-11	MYLAR 0.047UF 5.00% 50V	
				C1906	1-162-970-11	CERAMIC CHIP 0.01UF 10.00% 25V	
				C1908	1-109-954-11	ELECT 0.47UF 20.00% 160V	
				C1913	1-129-898-00	FILM 0.0022UF 5.00% 630V	
				C1915	1-136-205-11	MYLAR 0.022UF 10.00% 250V	
				C1917	1-102-228-00	CERAMIC 470PF 10.00% 500V	
				C1951	1-126-964-11	ELECT 10UF 20.00% 50V	
				C1952	1-126-964-11	ELECT 10UF 20.00% 50V	
				C1953	1-137-367-11	MYLAR 0.0033UF 5.00% 50V	
				C1954	1-162-970-11	CERAMIC CHIP 0.01UF 10.00% 25V	
				C1957	1-126-964-11	ELECT 10UF 20.00% 50V	
				C1958	1-136-169-00	FILM 0.22UF 5.00% 50V	



REF.NO.	PART.NO	DESCRIPTION	REMARK	REF.NO.	PART.NO	DESCRIPTION	REMARK
C1959	1-136-169-00	FILM 0.22UF 5.00% 50V		Q1707	8-729-049-09	TRANSISTOR BC327-25	
	< CONNECTOR >			Q1708	8-729-045-05	TRANSISTOR 2SA2005	
CN1701	1-691-771-11	PLUG (MICRO CONNECTOR) 9P		Q1709	8-729-119-78	TRANSISTOR 2SC2785-HFE	
CN1702	*1-564-506-11	PLUG, CONNECTOR 3P		Q1710	8-729-049-10	TRANSISTOR BC337-25	
CN1718	*1-770-723-11	CONNECTOR, BOARD TO BOARD 8P		Q1711	8-729-045-04	TRANSISTOR 2SC5511	
CN1809	1-695-915-11	TAB (CONTACT)		Q1840	8-729-119-76	TRANSISTOR 2SA1175-HFE	
	< DIODE >			Q1841	8-729-039-68	TRANSISTOR IRF620	
D1711	8-719-988-61	DIODE 1SS355TE-17		Q1901	8-729-120-28	TRANSISTOR 2SC1623-L5L6	
D1719	8-719-991-33	DIODE 1SS133T-77		Q1902	8-729-120-28	TRANSISTOR 2SC2412K-T-146-R	
D1722	8-719-991-33	DIODE 1SS133T-77		Q1903	8-729-043-95	TRANSISTOR 2SC3840(3)	
D1733	8-719-921-40	DIODE MTZJ-T-4.7C		Q1906	8-729-120-28	TRANSISTOR 2SC1623-L5L6	
D1734	8-719-921-40	DIODE MTZJ-T-4.7C		Q1907	8-729-140-97	TRANSISTOR 2SB734-34	
				< RESISTOR >			
D1840	8-719-302-43	DIODE EL1Z		JR1702	1-216-814-11	RES-CHIP 270 5% 1/16W	
D1901	8-719-991-33	DIODE 1SS133T-77		R1701	1-216-814-11	RES-CHIP 270 5% 1/16W	
D1902	8-719-991-33	DIODE 1SS133T-77		R1702	1-216-814-11	RES-CHIP 270 5% 1/16W	
D1903	8-719-991-33	DIODE 1SS133T-77		R1709	1-216-825-11	RES-CHIP 2.2K 5% 1/16W	
D1904	8-719-991-33	DIODE 1SS133T-77		R1710	1-216-839-11	RES-CHIP 33K 5% 1/16W	
D1905	8-719-110-41	DIODE RD15ESB2		R1711	1-216-823-11	RES-CHIP 1.5K 5% 1/16W	
D1906	8-719-970-87	DIODE ERA38-06		R1712	1-216-824-11	RES-CHIP 1.8K 5% 1/16W	
D1907	8-719-970-87	DIODE ERA38-06		R1713	1-216-809-11	RES-CHIP 100 5% 1/16W	
D1908	8-719-300-33	DIODE RU-3AM		R1714	1-260-089-11	CARBON 150 5% 1/2W	
D1909	8-719-991-33	DIODE 1SS133T-77		R1719	1-216-822-11	RES-CHIP 1.2K 5% 1/16W	
	< FERRITE BEAD >			R1720	1-249-433-11	CARBON 22K 5% 1/4W	
FB1701	1-535-143-61	LEAD, JUMPER (5.0MM)		R1721	1-249-433-11	CARBON 22K 5% 1/4W	
	< IC >			R1722	1-216-822-11	RES-CHIP 1.2K 5% 1/16W	
IC1701	8-759-394-36	IC BA09T		R1723	1-249-399-11	CARBON 33 5% 1/4W	
IC1901	8-759-450-95	IC LM393N		R1724	1-216-830-11	RES-CHIP 5.6K 5% 1/16W	
IC1902	8-759-008-70	IC LM358N		R1725	1-247-889-00	CARBON 270K 5% 1/4W	
	< COIL >			R1726	1-247-889-00	CARBON 270K 5% 1/4W	
L1701	1-414-183-41	INDUCTOR 10UH		R1727	1-216-830-11	RES-CHIP 5.6K 5% 1/16W	
L1702	1-412-525-31	INDUCTOR 10UH		R1728	1-249-399-11	CARBON 33 5% 1/4W	
L1703	1-414-184-41	INDUCTOR 15UH		R1729	1-249-407-11	CARBON 150 5% 1/4W	
L1843	1-406-989-21	INDUCTOR 10MH		R1732	1-249-407-11	CARBON 150 5% 1/4W	
L1901	1-406-677-11	INDUCTOR 10MH		R1733	1-214-809-81	METAL 5.1 1% 1/2W	
L1902	1-414-177-11	INDUCTOR 1UH		R1734	1-214-809-81	METAL 5.1 1% 1/2W	
	< COIL >			R1735	1-215-922-11	METAL OXIDE 6.8K 5% 3W	
L8802	1-406-978-11	INDUCTOR 150UH		R1736	1-215-892-11	METAL OXIDE 1K 5% 2W	
	< TRANSISTOR >			R1737	1-215-867-00	METAL OXIDE 470 5% 1W	
Q1701	8-729-120-28	TRANSISTOR 2SC1623-L5L6		R1739	1-535-143-61	LEAD, JUMPER (5.0MM)	
Q1704	8-729-120-28	TRANSISTOR 2SC1623-L5L6		R1842	1-216-809-11	RES-CHIP 100 5% 1/16W	
Q1705	8-729-119-78	TRANSISTOR 2SC2785-HFE		R1846	1-216-825-11	RES-CHIP 2.2K 5% 1/16W	
Q1706	8-729-026-39	TRANSISTOR 2SA933AS-QT		R1901	1-216-841-11	RES-CHIP 47K 5% 1/16W	
				R1903	1-216-833-11	RES-CHIP 10K 5% 1/16W	
				R1904	1-216-833-11	RES-CHIP 10K 5% 1/16W	
				R1905	1-216-845-11	RES-CHIP 100K 5% 1/16W	
				R1906	1-216-833-11	RES-CHIP 10K 5% 1/16W	
				R1907	1-216-845-11	RES-CHIP 100K 5% 1/16W	

REF.NO.	PART.NO	DESCRIPTION	REMARK	REF.NO.	PART.NO	DESCRIPTION	REMARK
L903	1-408-603-31	INDUCTOR	10UH	R7152	1-216-829-11	RES-CHIP	4.7K 5% 1/16W
L904	1-410-119-11	INDUCTOR	1MH	R7153	1-216-829-11	RES-CHIP	4.7K 5% 1/16W
	< RESISTOR >			R7154	1-216-825-11	RES-CHIP	2.2K 5% 1/16W
R901	1-249-427-11	CARBON	6.8K 5% 1/4W	R7155	1-216-809-11	RES-CHIP	100 5% 1/16W
R902	1-249-429-11	CARBON	10K 5% 1/4W	R7156	1-216-815-11	RES-CHIP	330 5% 1/16W
R903	1-249-406-11	CARBON	120 5% 1/4W				
R904	1-249-406-11	CARBON	120 5% 1/4W				
R909	1-247-895-91	CARBON	470K 5% 1/4W				
R910	1-247-895-91	CARBON	470K 5% 1/4W				
R911	1-249-419-11	CARBON	1.5K 5% 1/4W				
R912	1-535-143-61	LEAD, JUMPER (5.0MM)					
R913	1-247-843-11	CARBON	3.3K 5% 1/4W				
R914	1-249-431-11	CARBON	15K 5% 1/4W				
R915	1-249-406-11	CARBON	120 5% 1/4W				
R916	1-249-406-11	CARBON	120 5% 1/4W				
R917	1-247-807-31	CARBON	100 5% 1/4W				
R918	1-247-807-31	CARBON	100 5% 1/4W				
	< SWITCH >						
S900	1-692-979-11	SWITCH, TACTILE					
S901	1-692-979-11	SWITCH, TACTILE					
S902	1-692-979-11	SWITCH, TACTILE					
*A-1646-245-A H8 Board, Complete							
	1-682-340-15	PWB, H8					
	4-205-711-01	HOLDER, LED					
	< CAPACITOR >						
C7150	1-126-969-11	ELECT	220UF	20.00%	50V		
	< CONNECTOR >						
CN7150	*1-564-510-11	PLUG, CONNECTOR	7P				
	< DIODE >						
D7150	8-719-081-56	DIODE L-59SRSGC-CC					
D7152	8-719-109-89	DIODE RD5.6ESB2					
	< IC >						
IC7150	8-749-014-59	IC TSOP1740KS1					
	< TRANSISTOR >						
Q7150	8-729-027-38	TRANSISTOR DTA144EKA-T146					
Q7151	8-729-900-53	TRANSISTOR DTC114EK					
	< RESISTOR >						
R7150	1-216-813-11	RES-CHIP	220 5%	1/16W			
R7151	1-216-813-11	RES-CHIP	220 5%	1/16W			

Note : The components identified by shading and marked Δ are critical for safety. Replace only with the part numbers specified in the parts list.

REF.NO.	PART.NO	DESCRIPTION	REMARK	REF.NO.	PART.NO	DESCRIPTION	REMARK
MISCELLANEOUS							
Δ	1-571-433-21	SWITCH, PUSH (AC POWER)					
Δ	1-776-204-12	CORD, POWER (FILTER)					
	1-424-733-11	COIL, PFC CHOKE 65MMH					
Δ	1-453-308-41	TRANSFORMER ASSY, FLYBACK (NX-4521//Z2B4)					
	1-693-557-13	FRONT END (TUNER + IF)					
	8-598-585-00	FRONT END BTD-DU604					
	1-529-408-11	SPEAKER (4.2X24CM)					
Δ	8-737-786-05	PICTURE TUBE (W66LLX060X) (KD-28DX40)					
Δ	8-735-079-05	PICTURE TUBE (W76LLZ060X) (KD-32DX40)					
	8-451-521-11	DEFLECTION YOKE (Y28RVC3-B) (KD-28DX40)					
	8-451-520-11	DEFLECTION YOKE (Y32RVC3) (KD-32DX40)					
	1-452-896-11	COIL, NA ROTATION (RT-200)					
	8-453-011-11	NECK ASSY, (NA299-M)					
Δ	1-416-466-21	COIL, DEMAGNETIC (KD-28DX40)					
Δ	1-416-769-11	COIL, DEMAGNETIC (KD-32DX40)					
Δ	1-251-946-11	CAP ASSY, HIGH-VOLTAGE					
	1-452-094-00	MAGNET, ROTATABLE DISK; 15MM \emptyset					
	1-452-032-00	MAGNET, DISK; 10MM \emptyset					
ACCESSORIES AND PACKAGING MATERIALS							
	*4-395-957-01	BAG, PROTECTION (KD-28DX40)					
	*4-209-168-01	BAG, PROTECTION (KD-32DX40)					
	*4-205-504-02	CUSHION, UPPER (KD-28DX40)					
	*4-205-531-02	CUSHION, UPPER (KD-32DX40)					
	*4-205-505-03	CUSHION, LOWER (KD-28DX40)					
	*4-205-532-02	CUSHION, LOWER (KD-32DX40)					
	*4-205-503-01	INDIVIDUAL CARTON (KD-28DX40)					
	*4-205-530-01	INDIVIDUAL CARTON (KD-32DX40)					
	4-206-297-11	INSTRUCTION MANUAL (ENGLISH)					
REMOTE COMMANDER							
	1-476-697-11	COMMANDER, STANDARD (RM-933)					

TRACE

A new TV Repair Assistance Tool that combines ease of use and powerful PC software tools to allow you to save valuable time during many TV repairs.



The TRACE interface connects to the PC's serial port. It provides connection to the TV's I²C bus and can be provided with an InfraRed transmitter (optional).

The interface is powered by a standard 9 V PP3 battery for portable use, and can also be powered by an external 9V/25mA DC power supply.

The TRACE software that is supplied with the interface allows you to:

- Read, restore and compare NVM contents via the I²C bus
- Acknowledge check of all I²C devices in the TV set
- Read Error Codes (emulation of the Error Reader tool)

With the optional IR Add-on kit, the following features can be added:

- Remote Commander emulation
- User programmable Functional Check through Infrared
- Fast and documented Test Mode setting of all Sony TV chassis

Additional features such as Adjustments and Troubleshooting are available in chassis-dependent software modules. Please contact your local Sony Service organisation for the latest information.

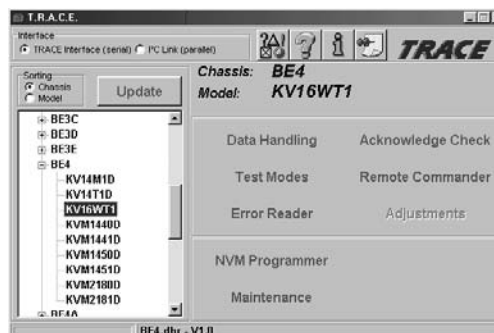

Note: For workshops already using the existing I²C Link parallel port interface (9-948-320-30), this software can be used as well, replacing the TV Data Handling software (9-948-340-50), but Error Reader and IR functions can only be accessed with the TRACE interface.

Partnumbers: TRACE Starter Kit (TRACE interface + software): 9-948-320-70
TRACE Software (for users of the I²C Link interface): 9-948-340-80
TRACE IR Add-on (IR interface + Remote Commander software): 9-948-320-80

PC requirements: IBM-compatible PC with operating system Windows95, Windows98, or WindowsNT*.

* WindowsNT only supported with TRACE interface

Sony Corporation
Sony UK
Service Promotions Dept.

English
01HP7100-1
Printed in U.K.
© 2001.8